



Administrator's Guide

Abstract

This book explains how to create and manage VoltDB databases and the clusters that run them.

V7.8

Administrator's Guide

V7.8

Copyright © 2014-2017 VoltDB Inc.

The text and illustrations in this document are licensed under the terms of the GNU Affero General Public License Version 3 as published by the Free Software Foundation. See the GNU Affero General Public License (<http://www.gnu.org/licenses/>) for more details.

Many of the core VoltDB database features described herein are part of the VoltDB Community Edition, which is licensed under the GNU Affero Public License 3 as published by the Free Software Foundation. Other features are specific to the VoltDB Enterprise Edition and VoltDB Pro, which are distributed by VoltDB, Inc. under a commercial license. Your rights to access and use VoltDB features described herein are defined by the license you received when you acquired the software.

VoltDB is a trademark of VoltDB, Inc.

VoltDB software is protected by U.S. Patent Nos. 9,600,514 and 9,639,571. Other patents pending.

This document was generated on October 23, 2017.

Table of Contents

Preface	vii
1. Structure of This Book	vii
2. Related Documents	vii
1. Managing VoltDB Databases	1
1.1. Getting Started	1
1.2. Understanding the VoltDB Utilities	2
1.3. Management Tasks	3
2. Preparing the Servers	4
2.1. Server Checklist	4
2.2. Install Required Software	4
2.3. Configure Memory Management	5
2.3.1. Disable Swapping	5
2.3.2. Disable Transparent Huge Pages	5
2.3.3. Enable Virtual Memory Mapping and Overcommit	6
2.4. Turn off TCP Segmentation	6
2.5. Configure NTP	7
2.6. Configure the Network	7
2.7. Assign Network Ports	8
3. Starting and Stopping the Database	9
3.1. Configuring the Cluster and Database	9
3.2. Initializing the Database Root Directory	10
3.3. Starting the Database	11
3.4. Loading the Database Definition	11
3.5. Stopping the Database	12
3.6. Restarting the Database	12
3.7. Starting and Stopping Individual Servers	13
4. Maintenance and Upgrades	14
4.1. Backing Up the Database	14
4.2. Updating the Database Schema	15
4.2.1. Performing Live Schema Updates	15
4.2.2. Performing Updates Using Save and Restore	15
4.3. Upgrading the Cluster	16
4.3.1. Performing Server Upgrades	16
4.3.2. Performing Rolling Hardware Upgrades on K-Safe Clusters	17
4.3.3. Adding Servers to a Running Cluster with Elastic Scaling	18
4.3.4. Reconfiguring the Cluster During a Maintenance Window	18
4.4. Upgrading VoltDB Software	19
4.4.1. Upgrading VoltDB Using Save and Restore	19
4.4.2. Upgrading Older Versions of VoltDB Manually	20
4.4.3. Upgrading VoltDB With Reduced Downtime Using a DR Replica	20
4.4.4. Performing an Online Upgrade Using Multiple XDCR Clusters	23
4.4.5. Performing an Online Upgrade With Limited Hardware	24
5. Deploying Clusters with the VoltDB Deployment Manager	28
5.1. Starting the VoltDB Deployment Manager	28
5.1.1. Starting the Deployment Manager Manually	28
5.1.2. Starting the Deployment Manager as a Service	28
5.2. What the Deployment Manager Does	29
5.3. How the Deployment Manager Works	29
5.4. Using the VoltDB Deployment Manager Web Interface	30
5.5. Using the VoltDB Deployment Manager REST API	31
6. Monitoring VoltDB Databases	33

6.1. Monitoring Overall Database Activity	33
6.1.1. VoltDB Management Center	33
6.1.2. System Procedures	33
6.1.3. SNMP Alerts	35
6.2. Setting the Database to Read-Only Mode When System Resources Run Low	37
6.2.1. Monitoring Memory Usage	38
6.2.2. Monitoring Disk Usage	38
6.3. Integrating VoltDB with Other Monitoring Systems	39
6.3.1. Integrating with Nagios	40
6.3.2. Integrating with New Relic	40
7. Logging and Analyzing Activity in a VoltDB Database	41
7.1. Introduction to Logging	41
7.2. Creating the Logging Configuration File	41
7.3. Enabling Logging for VoltDB	43
7.4. Changing the Timezone of Log Messages	43
7.5. Changing the Configuration on the Fly	44
8. What to Do When Problems Arise	45
8.1. Where to Look for Answers	45
8.2. Handling Errors When Restoring a Database	45
8.2.1. Logging Constraint Violations	46
8.2.2. Safe Mode Recovery	46
8.3. Collecting the Log Files	47
A. Server Configuration Options	49
A.1. Server Configuration Options	49
A.1.1. Network Configuration (DNS)	49
A.1.2. Time Configuration (NTP)	50
A.2. Process Configuration Options	50
A.2.1. Maximum Heap Size	50
A.2.2. Other Java Runtime Options (VOLTDB_OPTS)	50
A.3. Database Configuration Options	51
A.3.1. Sites per Host	51
A.3.2. K-Safety	51
A.3.3. Network Partition Detection	52
A.3.4. Read Level Consistency	52
A.3.5. Automated Snapshots	52
A.3.6. Import and Export	52
A.3.7. Command Logging	53
A.3.8. Heartbeat	53
A.3.9. Temp Table Size	53
A.3.10. Query Timeout	53
A.3.11. Long-Running Process Warning	54
A.4. Path Configuration Options	54
A.4.1. VoltDB Root	55
A.4.2. Snapshots Path	55
A.4.3. Export Overflow Path	55
A.4.4. Command Log Path	55
A.4.5. Command Log Snapshots Path	55
A.5. Network Ports	56
A.5.1. Client Port	56
A.5.2. Admin Port	57
A.5.3. Web Interface Port (httpd)	57
A.5.4. JSON Interface	57
A.5.5. Internal Server Port	58
A.5.6. Replication Port	58

A.5.7. Zookeeper Port	58
A.5.8. TLS/SSL Encryption (Including HTTPS)	59
B. Snapshot Utilities	60
snapshotconvert	61
snapshotverifier	62

List of Tables

1.1. Database Management Tasks	3
3.1. Selecting Database Features in the Configuration File	9
4.1. Overview of the Online Upgrade Process	25
5.1. REST API Objects and Methods	31
6.1. SNMP Configuration Attributes	35
6.2. SNMP Events	36
6.3. Nagios Plugins	40
7.1. VoltDB Components for Logging	43
A.1. VoltDB Port Usage	56

Preface

This book explains how to manage VoltDB databases and the clusters that host them. It is intended for database administrators and operators, responsible for the ongoing management and maintenance of database infrastructure.

1. Structure of This Book

This book is divided into 8 chapters and 2 appendices:

- Chapter 1, *Managing VoltDB Databases*
- Chapter 2, *Preparing the Servers*
- Chapter 3, *Starting and Stopping the Database*
- Chapter 4, *Maintenance and Upgrades*
- Chapter 5, *Deploying Clusters with the VoltDB Deployment Manager*
- Chapter 6, *Monitoring VoltDB Databases*
- Chapter 7, *Logging and Analyzing Activity in a VoltDB Database*
- Chapter 8, *What to Do When Problems Arise*
- Appendix A, *Server Configuration Options*
- Appendix B, *Snapshot Utilities*

2. Related Documents

This book does not describe how to design or develop VoltDB databases. For a complete description of the development process for VoltDB and all of its features, please see the accompanying manual *Using VoltDB*. For new users, see the *VoltDB Tutorial*. These and other books describing VoltDB are available on the web from <http://docs.voltdb.com/>.

Chapter 1. Managing VoltDB Databases

VoltDB is a distributed, in-memory database designed from the ground up to maximize throughput performance on commodity servers. The VoltDB architecture provides many advantages over traditional database products while avoiding the pitfalls of NoSQL solutions:

- By partitioning the data and stored procedures, VoltDB can process multiple queries in parallel without sacrificing the consistency or durability of an ACID-compliant database.
- By managing all data in memory with a single thread for each partition, VoltDB avoids overhead such as record locking, latching, and device-contention inherent in traditional disk-based databases.
- VoltDB databases can scale up to meet new capacity or performance requirements simply by adding more nodes to the cluster.
- Partitioning is automated, based on the schema, so there is no need to manually shard or repartition the data when scaling up as with many NoSQL solutions.
- Finally, VoltDB Enterprise Edition provides features to ensure durability and high availability through command logging, locally replicating partitions (K-safety), and wide-area database replication.

Each of these features is described, in detail, in the *Using VoltDB* manual. This book explains how to use these and other features to manage and maintain a VoltDB database cluster from a database administrator's perspective.

1.1. Getting Started

Before you set up VoltDB for use in a production environment, you need to make four decisions:

- **What database features to use** — Which features you want to use are defined in the configuration file and set with the **voltdb init** command.
- **Physical structure of the cluster** — The number and addresses of the nodes in the cluster, which you specify when you start the cluster with the **voltdb start** command.
- **Logical structure of the database** — The logical structure of the database tables and views, otherwise known as the *schema*, is defined in standard SQL statements and can be applied to the database using the **sqlcmd** command line utility.
- **Stored procedures** — The schema declares stored procedures. The procedures themselves execute transactions against the data and are written as Java classes. You load the stored procedures as JAR files using the **sqlcmd** command line utility.

To initialize a VoltDB database cluster, you need a configuration file. The *configuration file* lets you enable and configure various database options including availability, durability, and security. The configuration file also defines certain attributes of the database on the current server, in particular the paths for disk-based files created by the database such as command logs and snapshots. All nodes in the cluster must specify the same cluster configuration file when they initialize the database root directory with the **voltdb init** command.

When you actually start the database cluster, using the **voltdb start** command, you declare the size the cluster by specifying the number of nodes in the cluster and one or more of the nodes as potential hosts. VoltDB selects one of the specified nodes as the "leader" to coordinate startup.

When using the VoltDB Enterprise Edition, you will also need a license file, often called `license.xml`. VoltDB automatically looks for the license file in the user's current working directory, the home directory, or the `voltddb/` subfolder where VoltDB is installed. If you keep the license file in a different directory or under a different name, you can use the `--license` argument on the **voltddb start** command to specify the license file location.

Finally, to prepare the database for a specific application, you will need the database schema, including the DDL statements that describe the database's logical structure, and a JAR file containing the stored procedure class files. In general, the database schema and stored procedures are produced as part of the database development process, which is described in the *Using VoltDB* manual.

This book assumes the schema and stored procedures have already been created. The configuration file, on the other hand, defines the run-time configuration of the cluster. Establishing the correct settings for the configuration file and physically managing the database cluster is the duty of the administrators who are responsible for maintaining database operations. This book is written for those individuals and covers the standard procedures associated with database administration.

1.2. Understanding the VoltDB Utilities

VoltDB provides several command line utilities, each with a different function. Familiarizing yourself with these utilities and their uses can make managing VoltDB databases easier. The three primary command line tools for creating, managing, and testing VoltDB databases are:

voltddb	<p>Starts the VoltDB database process. The voltddb command can also collect log files for analyzing possible system errors (see Section 8.3, “Collecting the Log Files” for details).</p> <p>The voltddb command runs locally and does not require a running database.</p>
voltadmin	<p>Issues administrative commands to a running VoltDB database. You can use voltadmin to save and restore snapshots, pause and resume admin mode, and to shutdown the database, among other tasks.</p> <p>The voltadmin command can be run remotely, performs cluster-wide operations and requires a running database to connect to.</p>
sqlcmd	<p>Lets you issue SQL queries and invoke stored procedures interactively. The sqlcmd command is handy for testing database access without having to write a client application.</p> <p>The sqlcmd command can be run remotely and requires a running database to connect to.</p>

In addition to the preceding general-purpose tools, VoltDB provides several other tools for specific tasks:

csvloader	<p>Loads records from text files into an existing VoltDB database. The command's primary use is for importing data into VoltDB from CSV and other text-based data files that were exported from other data utilities,</p> <p>The csvloader command can be run remotely and requires a running database to connect to.</p>
snapshotconvert	<p>Converts native snapshot files to csv or tabbed text files. The snapshotconvert command is useful when exporting a snapshot in native format to text files for import into another data utility. (This utility is provided for legacy purposes. It is now pos-</p>

	<p>sible to write snapshots directly to CSV format without post-processing, which is the recommended approach.)</p> <p>The snapshotconvert command runs locally and does not require a running database.</p>
snapshotverify	<p>Verifies that a set of native snapshot files are complete and valid.</p> <p>The snapshotverify command runs locally and does not require a running database.</p>

Finally, VoltDB includes two browser-based administrative tools:

- VoltDB Deployment Manager — for configuring and starting VoltDB clusters
- VoltDB Management Center — for monitoring running databases in realtime

See Chapter 5, *Deploying Clusters with the VoltDB Deployment Manager* and Section 6.1.1, “VoltDB Management Center”, respectively, for more information about using these tools.

1.3. Management Tasks

Database administration responsibilities fall into five main categories, as described in Table 1.1, “Database Management Tasks”. The following chapters are organized by category and explain how to perform each task for a VoltDB database.

Table 1.1. Database Management Tasks

Preparing the Servers	Before starting the database, you must make sure that the server hardware and software is properly configured. This chapter provides a checklist of tasks to perform before starting VoltDB.
Basic Database Operations	The basic operations of initializing, starting, and stopping the database. This chapter describes the procedures needed to handle these fundamental tasks.
Maintenance and Upgrades	Over time, both the cluster and the database may require maintenance — either planned or emergency. This chapter explains the procedures for performing hardware and software maintenance, as well as standard maintenance, such as backing up the database and upgrading the hardware, the software, and the database schema.
Performance Monitoring	<p>Another important role for many database administrators is monitoring database performance. Monitoring is important for several reasons:</p> <ul style="list-style-type: none"> • Performance Analysis • Load Balancing • Fault Detection <p>This chapter describes the tools available for monitoring VoltDB databases.</p>
Problem Reporting & Analysis	If an error does occur and part or all of the database cluster fails, it is not only important to get the database up and running again, but to diagnose the cause of the problem and take corrective actions. VoltDB produces a number of log files that can help with problem resolution. This chapter describes the different logs that are available and how to use them to diagnose database issues.

Chapter 2. Preparing the Servers

VoltDB is designed to run on commodity servers, greatly reducing the investment required to operate a high performance database. However, out of the box, these machines are not necessarily configured for optimal performance of a dedicated, clustered application like VoltDB. This is especially true when using cloud-based services. This chapter provides best practices for configuring servers to maximize the performance and stability of your VoltDB installation.

2.1. Server Checklist

The very first step in configuring the servers is making sure you have sufficient memory, computing power, and system resources such as disk space to handle the expected workload. The *VoltDB Planning Guide* provides detailed information on how to size your server requirements.

The next step is to configure the servers and assign appropriate resources for VoltDB tasks. Specific server features that must be configured for VoltDB to perform optimally are:

- Install required software
- Configure memory management
- Turn off TCP Segmentation
- Configure NTP (time services)
- Define network addresses for all nodes in the cluster
- Assign network ports

2.2. Install Required Software

To start, VoltDB requires a recent release of the Linux operating system. The supported operating systems for running production VoltDB databases are:

- CentOS V6.6 or later. Including CentOS 7.0 and later
- Red Hat (RHEL) V6.6 or later, including Red Hat 7.0 and later
- Ubuntu 14.04 and 16.04

It may be possible to run VoltDB on other versions of Linux. Also, an official release for Macintosh OS X 10.9 and later is provided for development purposes. However, the preceding operating system versions are the only fully tested and supported base platforms for running VoltDB in production.

In addition to the base operating system, VoltDB requires the following software at a minimum:

- Java 8
- NTP
- Python 2.5 or later

Sun Java SDK 8 is recommended, but OpenJDK 8 is also supported. Note that although the VoltDB server requires Java 8, the Java client is also compatible with Java 7.

VoltDB works best when the system clocks on all cluster nodes are synchronized to within 100 milliseconds or less. However, the clocks are allowed to differ by up to 200 milliseconds before VoltDB refuses to start. NTP, the Network Time Protocol, is recommended for achieving the necessary synchronization. NTP is installed and enabled by default on many operating systems. However, the configuration may need adjusting (see Section 2.5, “Configure NTP” for details) and in cloud instances where hosted servers are run in a virtual environment, NTP is not always installed or enabled by default. Therefore you need to do this manually.

Finally, VoltDB implements its command line interface through Python. Python 2.4 or later is required to use the VoltDB shell commands.

2.3. Configure Memory Management

Because VoltDB is an in-memory database, proper memory management is vital to the effective operation of VoltDB databases. Three important aspects of memory management are:

- Swapping
- Memory Mapping (Transparent Huge Pages)
- Virtual memory

The following sections explain how best to configure these features for optimal performance of VoltDB.

2.3.1. Disable Swapping

Swapping is an operating system feature that optimizes memory usage when running multiple processes by swapping processes in and out of memory. However, any contention for memory, including swapping, will have a very negative impact on VoltDB performance and functionality. You should disable swapping when using VoltDB.

To disable swapping on Linux systems, use the `swaponoff` command. If swapping cannot be disabled for any reason, you can reduce the likelihood of VoltDB being swapped out by setting the kernel parameter `vm.swappiness` to zero.

2.3.2. Disable Transparent Huge Pages

Transparent Huge Pages (THP) are another operating system feature that optimizes memory usage for systems with large amounts of memory. THP changes the memory mapping to use larger physical pages. This can be helpful for general-purpose computing running multiple processes. However, for memory-intensive applications such as VoltDB, THP can actually negatively impact performance.

Therefore, it is important to disable Transparent Huge Pages on servers running VoltDB. The following commands, run as root or from another privileged account, disable THP:

```
$ echo never >/sys/kernel/mm/transparent_hugepage/enabled
$ echo never >/sys/kernel/mm/transparent_hugepage/defrag
```

Or:

```
$ echo madvise >/sys/kernel/mm/transparent_hugepage/enabled
$ echo madvise >/sys/kernel/mm/transparent_hugepage/defrag
```

For RHEL systems (including CentOS), replace "transparent_hugepage" with "redhat_transparent_hugepage".

Note, however, that these commands disable THP only while the server is running. Once the server reboots, the default setting will return. Therefore, we recommend you disable THP permanently as part of the startup process. For example, you can add the following commands to a server startup script (such as `/etc/rc.local`):

```
#!/bin/bash
for f in /sys/kernel/mm/*transparent_hugepage/enabled; do
    if test -f $f; then echo never > $f; fi
done
for f in /sys/kernel/mm/*transparent_hugepage/defrag; do
    if test -f $f; then echo never > $f; fi
done
```

THP are enabled by default in Ubuntu 14.04 and later as well as RHEL 6.x and 7.x. To see if they are enabled on your current system, use either of the following pair of commands:

```
$ cat /sys/kernel/mm/transparent_hugepage/enabled
$ cat /sys/kernel/mm/transparent_hugepage/defrag

$ cat /sys/kernel/mm/redhat_transparent_hugepage/enabled
$ cat /sys/kernel/mm/redhat_transparent_hugepage/defrag
```

If THP is disabled, the output from the preceding commands should be either “always madvise [never]” or “always [madvise] never”.

2.3.3. Enable Virtual Memory Mapping and Overcommit

Although swapping is bad for memory-intensive applications like VoltDB, the server does make use of virtual memory (VM) and there are settings that can help VoltDB make effective use of that memory. First, it is a good idea to enable VM overcommit. This avoids VoltDB encountering unnecessary limits when managing virtual memory. This is done on Linux by setting the system parameter `vm.overcommit_memory` to a value of “1”.

```
$ sysctl -w vm.overcommit_memory=1
```

Second, for large memory systems, it is also a good idea to increase the VM memory mapping limit. So for servers with 64 Gigabytes or more of memory, the recommendation is to increase VM memory map count to 1048576. You do this on Linux with the system parameter `max_map_count`. For example:

```
$ sysctl -w vm.max_map_count=1048576
```

Remember that for both overcommit and the memory map count, the parameters are only active while the system is running and will be reset to the default on reboot. So be sure to add your new settings to the file `/etc/sysctl.conf` to ensure they are in effect when the system is restarted.

2.4. Turn off TCP Segmentation

Under certain conditions, the use of TCP segmentation offload (TSO) and generic receive offload (GRO) can cause nodes to randomly drop out of a cluster. These settings let the system to batch network packets, producing unnecessary latency and interfering with the necessary communication between VoltDB cluster nodes. The symptoms of this problem are that nodes timeout — that is, the rest of the cluster thinks they have failed — although the node is still running and no other network issues (such as a network partition) are the cause.

Disabling TSO and GRO is recommended for any VoltDB clusters that experience such instability. The commands to disable offloading are the following, where N is replaced by the number of the ethernet card:

```
ethtool -K ethN tso off
ethtool -K ethN gro off
```

Note that these commands disable offloading temporarily. You must issue these commands every time the node reboots or, preferably, put them in a startup configuration file.

It is also a good idea to check that TCP_RETRIES2 has not been altered. Setting TCP_RETRIES2 too low (below 8) can cause similar unpredictable timeouts. See the description of the VoltDB heartbeat timeout setting in Section A.3.8, “Heartbeat” for details.

2.5. Configure NTP

To orchestrate activities between the cluster nodes, VoltDB relies on the system clocks being synchronized. Many functions within VoltDB — such as cluster start up, nodes rejoining, and schema updates among others — are sensitive to variations in the time values between nodes in the cluster. Therefore, it is important to keep the clocks synchronized within the cluster. Specifically:

- The server clocks in the cluster must be synchronized to within 200 milliseconds of each other when the cluster starts. (Ideally, skew between nodes should be kept under 10 milliseconds.)
- Time must not move backwards

The easiest way to achieve these goals is to install and configure the NTP (Network Time Protocol) service to use a common time host server for synchronizing the servers. NTP is often installed by default but may require additional configuration to achieve acceptable synchronization. Specifically, listing only one time server (and the same one for all nodes in the cluster) ensures minimal skew between servers. You can even establish your own time server to facilitate this. All nodes in the cluster should also list each other as peers. For example, the following NTP configuration file uses a local time server (myntpsvr) and establishes all nodes in the cluster as peers:

```
server myntpsvr burst iburst minpoll 4 maxpoll 4

peer voltsvr1 burst iburst minpoll 4 maxpoll 4
peer voltsvr2 burst iburst minpoll 4 maxpoll 4
peer voltsvr3 burst iburst minpoll 4 maxpoll 4

server 127.127.0.1
```

See the chapter on Configuring NTP in the *Guide to Performance and Customization* for more details on setting up NTP.

2.6. Configure the Network

It is also important to ensure that the network is configured correctly so all of the nodes in the VoltDB cluster recognize each other. If the DNS server does not contain entries for all of the servers in the cluster, an alternative is to add entries in the `/etc/hosts` file locally for each server in the cluster. For example:

```
12.24.48.101 voltsvr1
12.24.48.102 voltsvr2
12.24.48.103 voltsvr3
12.24.48.104 voltsvr4
```

12.24.48.105 voltsvr5

2.7. Assign Network Ports

VoltDB uses a number of network ports for functions such as internal communications, client connections, rejoin, database replication, and so on. For these features to perform properly, the ports must be open and available. Review the following list of ports to ensure they are open and available (that is, not currently in use).

Function	Default Port Number
Client Port	21212
Admin Port	21211
Web Interface Port (httpd)	8080
Internal Server Port	3021
Replication Port	5555
Zookeeper port	7181

Alternately, you can reassign the port numbers that VoltDB uses. See Section A.5, “Network Ports” for a description of the ports and how to reassign them.

Chapter 3. Starting and Stopping the Database

The fundamental operations for database administration are starting and stopping the database. But before you start the database, you need to decide what database features you want to enable and how they should work. These features include attributes such as the amount of replication you want to use to increase availability in case of server failure and what level of durability is required for those cases where the database itself stops. These and other settings are defined in the configuration file, which you specify on the command line when you initialize the root directory for the database on each server.

This chapter explains how to configure the cluster's physical structure and features in the configuration file and how to initialize the root directory and start and stop the database.

3.1. Configuring the Cluster and Database

You specify the cluster configuration and what features to use in the configuration file, which is an XML file that you can create and edit manually. In the simplest case, the configuration file specifies how many partitions to create on each server, and what level of availability (K-safety) to use. For example:

```
<?xml version="1.0"?>
<deployment>
  <cluster sitesperhost="12"
          kfactor="1"
  />
</deployment>
```

- The `sitesperhost` attribute specifies the number of partitions (or "sites") to create on each server. Set to eight by default, it is possible to optimize the number of sites per host in relation to the number of processors per machine. The optimal number is best determined by performance testing against the expected workload. See the chapter on "Benchmarking" in the *VoltDB Planning Guide* for details.
- The `kfactor` attribute specifies the K-safety value to use. The higher the K-safety value, the more node failures the cluster can withstand without affecting database availability. However, increasing the K-safety value increases the number of copies of each unique partition. High availability is a trade-off between replication to protect against node failure and the number of unique partitions, therefore throughput performance. See the chapter on availability in the *Using VoltDB* manual for more information on determining an optimal K-safety value.

In addition to the sites per host and K-safety, you can use the configuration file to enable and configure specific database features such as export, command logging, and so on. The following table summarizes some of the key features that are settable in the configuration file.

Table 3.1. Selecting Database Features in the Configuration File

Feature	Example
Command Logging — Command logging provides durability by logging transactions to disk so they can be replayed during a recovery. You can configure the type of command logging (synchronous or asynchronous), the log file size, and the frequency of the logs (in	<pre><commandlog enabled="true" synchronous="false"> <frequency time="300" transactions="1000"/> </commandlog></pre>

Feature	Example
terms of milliseconds or number of transactions).	
Snapshots — Automatic snapshots provide another form of durability by creating snapshots of the database contents, that can be restored later. You can configure the frequency of the snapshots, the unique file prefix, and how many snapshots are kept at any given time.	<pre><snapshot enabled="true" frequency="30m" prefix="mydb" retain="3" /></pre>
Export — Export allows you to write selected records from the database to one or more external targets, which can be files, another database, or another service. VoltDB provides different export connectors for each protocol. You can configure the type of export for each stream as well as other properties, which are specific to the connector type. For example, the file connector requires a specific type (or format) for the files and a unique identifier called a "nonce".	<pre><export> <configuration enabled="true" type="file"> <property name="type">csv</property> <property name="nonce">mydb</property> </configuration> </export></pre>
Security & Accounts — Security lets you protect your database against unwanted access by requiring all connections authenticate against known usernames and passwords. In the deployment file you can define the user accounts and passwords and what role or roles each user fulfills. Roles define what permissions the account has. Roles are defined in the database schema.	<pre><security enabled="true"/> <users> <user name="admin" password="superman" roles="dev,ops" /> <user name="mitty" password="thurber" roles="user" /> </users></pre>
File Paths — Paths define where VoltDB writes any files or other disc-based content. You can configure specific paths for each type of service, such as snapshots, command logs, export overflow, etc.	<pre><paths> <exportoverflow path="/tmp/overflow" /> <snapshots path="/opt/archive" /> </paths></pre>

3.2. Initializing the Database Root Directory

Once you create the configuration file, you are ready to initialize the database root directory, using the **voltdb init** command. You issue this command on each node of the cluster, specifying the configuration file and the location for the root directory. For example:

```
$ voltdb init --dir=~/database          ❶
              --config=deployment.xml   ❷
```

On the command line, you specify two arguments:

- ❶ The location where the root directory will be created
- ❷ The configuration file, which enables and sets attributes for specific VoltDB features

When you initialize the root directory, VoltDB:

1. Creates the root directory (voltdbroot) as a subfolder of the specified parent directory

2. Saves the configuration options in the new root directory

Note that you only need to initialize the root directory once. Once the root directory is initialized, you can start and stop the database as needed. VoltDB uses the root directory to manage the current configuration options and backups of the data — if those features are selected — in command logs and snapshots.

If the root directory already exists or has been initialized before, you cannot re-initialize the directory unless you include the `--force` argument. This is to protect you against accidentally deleting data from a previous database session.

3.3. Starting the Database

Once you initialize the root directory, you are ready to start the database using the **`voltodb start`** command. You issue this command, specifying the location of the root directory, the number of servers required, and one or more server addresses to use as "host" to manage the initial formation of the cluster. You issue the same command on every node in the cluster. For example:

```
$ voltodb start --dir=~/database      \ ❶  
               --count=5             \ ❷  
               --host=svr1,svr2      \ ❸  
               --license=~/license.xml ❹
```

On the command line, you specify four arguments:

- ❶ The location of the root directory
- ❷ The number of servers in the cluster
- ❸ One or more nodes from the cluster to use as the "host", to coordinate the initial startup of the cluster
- ❹ The license file (when using the VoltDB Enterprise Edition)

You must specify the same number of servers and hosts (listed in exactly the same order) on all nodes of the cluster. You can, optionally, specify *all* nodes of the cluster in the `--host` argument. In which case, you can leave off the `--count` argument and VoltDB assumes the number of hosts is the total number of servers.

When you start the database, all nodes select one of the servers from the host list as the "host". The host then:

1. Waits until the necessary number of servers (as specified by the count) are connected
2. Creates the network mesh between the servers
3. Verifies that the configuration options match for all nodes

At this point, the cluster is fully initialized and the "host" ends its special role and becomes a peer to all the other nodes. If the database was run before and command logs or automated snapshots exist, the cluster now recovers the data from the previous session. All nodes in the cluster then write an informational message to the console verifying that the database is ready:

```
Server completed initialization.
```

3.4. Loading the Database Definition

Responsibility for loading the database schema and stored procedures varies from company to company. In some cases, operators and administrators are only responsible for initiating the database; developers may load and modify the schema themselves. In other cases, the administrators are responsible for both starting the cluster and loading the correct database schema as well.

If you are responsible for establishing the correct schema, the next step is to load the Java stored procedures and the schema definition. Stored procedures are compiled into classes and then packaged into a JAR file, as described in the section on installing stored procedures in the *Using VoltDB* manual. To fully load the database definition you will need the JAR of stored procedure classes and a text file containing the data definition language (DDL) statements that declare the database schema.

The following example assumes these two files are `storedprocs.jar` and `dbschema.sql`. Once the database cluster has started, you can load the schema and stored procedures using the `sqlcmd` utility. To load them at the `sqlcmd` prompt, you can use the `sqlcmd load classes` and `file` directives:

```
$ sqlcmd
1> load classes storedprocs.jar;
2> file dbschema.sql;
```

Note that when loading the schema, you should always load the stored procedures first, so the class files are available for any `CREATE PROCEDURE` statements within the schema.

3.5. Stopping the Database

How you choose to stop a VoltDB depends on what features you have enabled. If you are using command logging (which is enabled by default in the VoltDB Enterprise Edition), it is a good idea to perform an orderly shutdown when stopping the database to ensure that all active client queries have a chance to complete and return their results (and no new queries start) before the shutdown occurs.

To perform an orderly shutdown you can use the `voltadmin shutdown` command:

```
$ voltadmin shutdown
```

As with all `voltadmin` commands, you can use them remotely by specifying one of the cluster servers on the command line:

```
$ voltadmin shutdown --host=voltsvr2
```

If security is enabled, you will also need to specify a username and password for a user with admin permissions:

```
$ voltadmin shutdown --host=voltsvr2 -u root -p Suda51
```

If you are not using command logging, you want to make sure you perform a snapshot before shutting down. You can do this manually using the `voltadmin save` command. Or you can simply add the `--save` argument to the `voltadmin shutdown` command:

```
$ voltadmin shutdown --save
```

The most recent snapshot saved to the database snapshots directory (by the `voltadmin save` command to the default location, automated snapshots, or `voltadmin shutdown --save`) will automatically be restored by the next `voltadmin start` command.

3.6. Restarting the Database

Restarting a VoltDB database is done the same way as starting the database for the first time, except there is no need to initialize the root directory. You simply issue the same `voltadmin start` command you did when you started it for the first time. For example:

```
$ voltadmin start --dir=~/database \
```

```
--count=5          \  
--host=svr1,svr2   \  
--license=~/.license.xml
```

If you are using command logging, or you created a snapshot in the default snapshots directory, VoltDB automatically reinstates the data once the cluster is established. After the schema is loaded and all data is restored, the database enables client access.

3.7. Starting and Stopping Individual Servers

When using K-safety, it is possible for one or more nodes in a cluster to stop without stopping the database itself. (See the chapter on availability in the Using VoltDB manual for a complete description of K-safety.) If a server stops — either intentionally or accidentally — you can start the server and have it rejoin the cluster using the same **voltadb start** command used to start the cluster. For example:

```
$ voltadb start --dir=~/.database    \  
               --count=5            \  
               --host=svr1,svr2     \  
               --license=~/.license.xml
```

The start command will check to see if the cluster is still running, based on the list of servers in the `--host` argument. If so, the server will rejoin the cluster.

Note that if there are multiple servers listed in the `--host` argument, the server can rejoin even if it is one of the listed hosts. If you only list one host and that is the server that stopped, you will need to list a different server in the `--host` argument — any server that is still an active member of the running cluster. (This is why listing multiple nodes in the `--host` argument is beneficial: you can use exactly the same start command in multiple situations.)

If you want to stop a single node in a K-safe cluster — for example, to perform maintenance on the hardware — you can do this using the **voltadmin stop** command. The **voltadmin stop** command stops a single node, as long as the cluster has enough K-safety to remain viable after the nodes stops. (If not, the **stop** command is rejected.) For example to stop `svr2`, you can issue the following command:

```
$ voltadmin stop --host=svr1 svr2
```

Note that the stop command does not have to be issued on the server that is being stopped. You can issue the command on any active server in the cluster. See Chapter 4, *Maintenance and Upgrades* for more information about performing maintenance tasks.

Chapter 4. Maintenance and Upgrades

Once the database is running, it is the administrator's role to keep it running. This chapter explains how to perform common maintenance and upgrade tasks, including:

- Database backups
- Schema and stored procedure updates
- Software and hardware upgrades

4.1. Backing Up the Database

It is a common safety precaution to backup all data associated with computer systems and store copies off-site in case of system failure or other unexpected events. Backups are usually done on a scheduled basis (every day, every week, or whatever period is deemed sufficient).

VoltDB provides several options for backing up the database contents. The easiest option is to save a native snapshot then backup the resulting snapshot files to removable media for archiving. The advantage of this approach is that native snapshots contain both a complete copy of the data and the schema. So in case of failure the snapshot can be restored to the current or another cluster using a single **voltadmin restore** command.

The key thing to remember when using native snapshots for backup is that each server saves its portion of the database locally. So you must fetch the snapshot files for all of the servers to ensure you have a complete set of files. The following example performs a manual snapshot on a five node cluster then uses scp to remotely copy the files from each server to a single location for archiving.

```
$ voltadmin save --blocking --host=voltsvr3 \  
    /tmp/voltdb backup  
$ scp -l 100 'voltsvr1:/tmp/voltdb/backup*' /tmp/archive/  
$ scp -l 100 'voltsvr2:/tmp/voltdb/backup*' /tmp/archive/  
$ scp -l 100 'voltsvr3:/tmp/voltdb/backup*' /tmp/archive/  
$ scp -l 100 'voltsvr4:/tmp/voltdb/backup*' /tmp/archive/  
$ scp -l 100 'voltsvr5:/tmp/voltdb/backup*' /tmp/archive/
```

Note that if you are using automated snapshots or command logging (which also creates snapshots), you can use the automated snapshots as the source of the backup. However, the automated snapshots use a programmatically generated file prefix, so your backup script will need some additional intelligence to identify the most recent snapshot and its prefix.

The preceding example also uses the scp limit flag (-l 100) to constrain the bandwidth used by the copy command to 100kbits/second. Use of the -l flag is recommended to avoid the copy operation blocking the VoltDB server process and impacting database performance.

Finally, if you wish to backup the data in a non-proprietary format, you can use the **voltadmin save --format=csv** command to create a snapshot of the data as comma-separated value (CSV) formatted text files. The advantage is that the resulting files are usable by more systems than just VoltDB. The disadvantage is that the CSV files only contain the data, not the schema. These files cannot be read directly into VoltDB, like a native snapshot can. Instead, you will need to initialize and start a new database, load the schema, then use the **csvloader** utility to load individual files into each table to restore the database completely.

4.2. Updating the Database Schema

As an application evolves, the database schema often needs changing. This is particularly true during the early stages of development and testing but also happens periodically with established applications, as the database is tuned for performance or adjusted to meet new requirements. In the case of VoltDB, these updates may involve changes to the table definitions, to the indexes, or to the stored procedures. The following sections explain how to:

- Perform live schema updates
- Change unique indexes and partitioning using save and restore

4.2.1. Performing Live Schema Updates

There are two ways to update the database schema for a VoltDB database: live updates and save/restore updates. For most updates, you can update the schema while the database is running. To perform this type of live update, you use the DDL CREATE, ALTER, and DROP statements to modify the schema interactively as described in the section on modifying the schema in the *Using VoltDB* manual.

You can make any changes you want to the schema as long as the tables you are modifying do not contain any data. The only limitations on performing live schema changes are that you cannot:

- Add or broaden unique constraints (such as indexes or primary keys) on tables with existing data
- Reduce the datatype size of columns on tables with existing data (for example, changing the datatype from INTEGER to TINYINT)

These limitations are in place to guarantee that the schema change will succeed without any pre-existing data violating the constraint. If you know that the data in the database does not violate the new constraints you can make these changes using the **save** and **restore** commands, as described in the following section.

4.2.2. Performing Updates Using Save and Restore

If you need to add unique indexes or reduce columns to database tables with existing data, you must use the **voltadmin save** and **restore** commands to perform the schema update. This requires shutting down and restarting the database to allow VoltDB to validate the existing data against the new constraints.

To perform a schema update using save and restore, use the following steps:

1. Create a new schema file containing the updated DDL statements.
2. Pause the database (**voltadmin pause**).
3. Save a snapshot of the database contents to an specific location (**voltadmin save --blocking {path} {file-prefix}**).
4. Shutdown the database (**voltadmin shutdown**).
5. Re-initialize and restart the database starting in admin mode (**voltadb init --force** and **voltadb start --pause**).
6. Load the stored procedures and new schema (using the sqlcmd **LOAD CLASSES** and **FILE** directives)
7. Restore the snapshot created in Step #3 (**voltadmin restore {path} {file-prefix}**).
8. Return the database to normal operations (**voltadmin resume**).

For example:

```
$ # Issue once
$ voltadmin pause
$ voltadmin save --blocking /opt/archive/ mydb
$ voltadmin shutdown

$ # Issue next two commands on all servers
$ voltdb init --dir=~ /mydb --config=deployment.xml --force
$ voltdb start --dir=~ /mydb --host=svr1,svr2 --count=5

$ # Issue only once
$ sqlcmd
1> load classes storedprocs.jar;
2> file newschema.sql;

3> exit
$ voltadmin restore /opt/archive mydb
$ voltadmin resume
```

The key point to remember when adding new constraints is that there is the possibility that the restore operation will fail if existing records violate the new constraint. This is why it is important to make sure your database contents are compatible with the new schema before performing the update.

4.3. Upgrading the Cluster

Sometimes you need to update or reconfigure the server infrastructure on which the VoltDB database is running. Server upgrades are one example. A *server upgrade* is when you need to fix or replace hardware, update the operating system, or otherwise modify the underlying system.

Server upgrades usually require stopping the VoltDB database process on the specific server being serviced. However, if your database cluster uses K-safety for enhanced availability, it is possible to complete server upgrades without any database downtime by performing a *rolling hardware upgrade*, where each server is upgraded in turn using the **voltadmin stop** and **start** commands.

Another type of upgrade is when you want to reconfigure the cluster as a whole. Reasons for reconfiguring the cluster are because you want to add or remove servers from the cluster or you need to modify the number of partitions per server that VoltDB uses.

Adding servers to the cluster can happen without stopping the database. This is called *elastic scaling*. Removing servers or changing the number of sites per host requires restarting the cluster during a *maintenance window*.

The following sections describe four methods of cluster upgrade:

- Performing server upgrades
- Performing rolling upgrades on K-safe clusters
- Adding servers to a running cluster through elastic scaling
- Reconfiguring the cluster with a maintenance window

4.3.1. Performing Server Upgrades

If you need to upgrade or replace the hardware or software (such as the operating system) of the individual servers, this can be done without taking down the database as a whole. As long as the server is running with a K-safety value of one or more, it is possible to take a server out of the cluster without stopping the

database. You can then fix the server hardware, upgrade software (other than VoltDB), even replace the server entirely with a new server, then bring the server back into the cluster.

To perform a server upgrade:

1. Stop the VoltDB server process on the server using the **voltadmin stop** command. As long as the cluster is K-safe, the rest of the cluster will continue running.
2. Perform the necessary upgrades.
3. Have the server rejoin the cluster using the **voltadb start** command.

The **start** command starts the database process on the server, contacts the database cluster, then copies the necessary partition content from other cluster nodes so the server can then participate as a full member of the cluster. While the server is rejoining, the other database servers remain accessible and actively process queries from client applications.

When rejoining a cluster you can use the same **start** command used when starting the cluster as a whole. If, however, you need to replace the server (say, for example, in the case of a disk failure), you will also need to initialize a root directory for the database process on the new machine. You do this using the current configuration file for the cluster. For example:

```
$ voltdb init --dir=~/database --config=deployment.xml
$ voltdb start --dir=~/database --host=svr1,svr2
```

If no changes have been made, you can use the same configuration file used to initialize the other servers. If you have used **voltadmin update** to change the configuration or changed settings using the VoltDB Management Center (VMC), you can download a copy of the latest configuration from VMC.

If the cluster is not K-safe — that is, the K-safety value is 0 — then you must follow the instructions in Section 4.3.4, “Reconfiguring the Cluster During a Maintenance Window” to upgrade the servers.

4.3.2. Performing Rolling Hardware Upgrades on K-Safe Clusters

If you need to upgrade all of the servers in a K-safe cluster (for example, if you are upgrading the operating system), you can perform a rolling hardware upgrade by stopping, upgrading, then rejoining each server one at a time. Using this process the entire cluster can be upgraded without suffering any downtime of the database. Just be sure to wait until the rejoining server has become a full member of the cluster before removing and upgrading the next server in the rotation. Specifically, wait until the following message appears in the log or on the console for the rejoining server:

```
Node rejoin completed.
```

Alternately, you can attempt to connect to the server remotely — for example, using the **sqlcmd** command line utility. If your connection is rejected, the rejoin has not finished. If you successfully connect to the client port of the rejoining node, you know the rejoin is complete:

```
$ sqlcmd --servers=myserver
SQL Command :: myserver:21212
1>
```

Note

You *cannot* update the VoltDB software itself using the rolling hardware upgrade process, only the operating system, hardware, or other software. See Section 4.4, “Upgrading VoltDB Software” for information about minimizing downtime during a VoltDB software upgrade.

4.3.3. Adding Servers to a Running Cluster with Elastic Scaling

If you want to add servers to a VoltDB cluster — usually to increase performance and/or capacity — you can do this without having to restart the database. You add servers to the cluster using the **voltadb start** command with the **--add** flag. Note, as always, you must initialize a root directory before issuing the **start** command. For example:

```
$ voltadb init --dir=~/database --config=deployment.xml
$ voltadb start --dir=~/database --host=svr1,svr2 --add
```

The **--add** flag specifies that if the cluster full — that is, all of the specified number of servers are currently active in the cluster — the joining node can be added to elastically expand the cluster. You must elastically add a full complement of servers to match the K -safety value ($K+1$) before the servers can participate as active members of the cluster. For example, if the K -safety value is 2, you must add 3 servers before they actually become part of the cluster and the cluster rebalances its partitions.

When you add servers to a VoltDB database, the cluster performs the following actions:

1. The new servers are added to the cluster configuration and sent copies of the schema, stored procedures, and deployment file.
2. Once sufficient servers are added, copies of all replicated tables and their share of the partitioned tables are sent to the new servers.
3. As the data is rebalanced, the new servers begin processing transactions for the partition content they have received.
4. Once rebalancing is complete, the new servers are full members of the cluster.

If the cluster is *not* at its full complement of servers when you issue a **voltadb start --add** command, the added server will join the cluster as a replacement for a missing node rather than extending the cluster. Once the cluster is back to its full complement of nodes, the next **voltadb start --add** command will extend the cluster.

4.3.4. Reconfiguring the Cluster During a Maintenance Window

If you want to remove servers from the cluster permanently (as opposed to temporarily removing them for maintenance as described in Section 4.3, “Upgrading the Cluster”) or you want to change other cluster-wide attributes, such as the number of partitions per server, you need to restart the database cluster as a whole. Stopping the database temporarily to perform this sort of reconfiguration is known as a *maintenance window*.

The steps for reconfiguring the cluster with a maintenance window are:

1. Place the database in admin mode (**voltadmin pause**).
2. Perform a manual snapshot of the database (**voltadmin save --blocking**).
3. Shutdown the database (**voltadmin shutdown**).
4. Make the necessary changes to the configuration file.
5. Reinitialize the database root directory on all nodes specifying the edited configuration file (**voltadb init --force**).

6. Start the new database in admin mode (**voltadb start --pause**)
7. Restore the snapshot created in Step #2 (**voltadmin restore**).
8. Return the database to normal operations (**voltadmin resume**).

4.4. Upgrading VoltDB Software

As new versions of VoltDB become available, you will want to upgrade the VoltDB software on your database cluster. The simplest approach for upgrading recent versions of VoltDB — V6.8 or later — is to perform an orderly shutdown saving a final snapshot, upgrade the software on all servers, then re-start the database. (If you are upgrading from earlier versions of the software, you can still upgrade using a snapshot. But you will need to perform the save and restore operations manually.)

However, upgrading using snapshots involves downtime while the software is being updated. An alternative is to use database replication (DR) — either passive DR or cross data center replication (XDCR) — to upgrade with minimal or no downtime.

Using passive DR you can copy the active database contents to a new cluster, then switch the application clients to point to the new server. The advantage of this process is that the only downtime the business application sees is the time needed to promote the new cluster and redirect the clients.

Using cross data center replication (XDCR), it is possible to perform an *online upgrade*, where there is no downtime and the database is accessible throughout the upgrade operation. If two or more clusters are already active participants in an XDCR environment, you can shutdown and upgrade the clusters, one at a time, to perform the upgrade leaving at least one cluster available at all times.

You can also use XDCR to upgrade a cluster, with limited extra hardware, by operationally splitting the cluster into two. Although this approach does not require downtime, it does reduce the K-safety for the duration of the upgrade.

The following sections describe all five approaches:

- Upgrading VoltDB Using Save and Restore
- Upgrading Older Versions of VoltDB Manually
- Upgrading VoltDB With Reduced Downtime Using a DR Replica
- Performing an Online Upgrade Using Multiple XDCR Clusters
- Performing an Online Upgrade With Limited Hardware

4.4.1. Upgrading VoltDB Using Save and Restore

Upgrading the VoltDB software on a single database cluster is easy. All you need to do is perform an orderly shutdown saving a final snapshot, upgrade the VoltDB software on all servers in the cluster, then restart the database. The steps to perform this procedure are:

1. Shutdown the database and save a final snapshot (**voltadmin shutdown --save**).
2. Upgrade VoltDB on all cluster nodes.
3. Restart the database (**voltadb start**).

This process works for any recent (V6.8 or later) release of VoltDB.

4.4.2. Upgrading Older Versions of VoltDB Manually

To upgrade older versions of VoltDB software (prior to V6.8), you must perform the save and restore operations manually. The steps when upgrading from older versions of VoltDB are:

1. Place the database in admin mode (**voltadmin pause**).
2. Perform a manual snapshot of the database (**voltadmin save --blocking**).
3. Shutdown the database (**voltadmin shutdown**).
4. Upgrade VoltDB on all cluster nodes.
5. Re-initialize the root directory on all nodes (**voltadb init --force**).
6. Start a new database in admin mode (**voltadb start --pause**).
7. Restore the snapshot created in Step #2 (**voltadmin restore**).
8. Return the database to normal operations (**voltadmin resume**).

4.4.3. Upgrading VoltDB With Reduced Downtime Using a DR Replica

When upgrading the VoltDB software in a production environment, it is possible to minimize the disruption to client applications by upgrading across two clusters using passive database replication (DR). To use this process you need a second database cluster to act as the DR replica and you must have a unique cluster ID assigned to the current database.

The basic process for upgrading the VoltDB software using DR is to:

1. Install the new VoltDB software on the secondary cluster
2. Use passive DR to synchronize the database contents from the current cluster to the new cluster
3. Pause the current database and promote the new cluster, switching the application clients to the new upgraded database

The following sections describe in detail the prerequisites for using this process, the steps to follow, and — in case there are any issues with the updated database — the process for falling back to the previous software version.

4.4.3.1. Prerequisites for Upgrading with Passive DR

The prerequisites for using DR to upgrade VoltDB are:

- A second cluster with the same configuration (that is, the same number of servers and sites per host) as the current database cluster.
- The current database cluster must have a unique cluster ID assigned in its deployment file.

The cluster ID is assigned in the `<dr>` section of the deployment file and must be set when the cluster starts. It cannot be added or altered while the database is running. So if you are considering using this process for upgrading your production systems, be sure to add a `<dr>` tag to the deployment and assign a unique cluster ID when starting the database, even if you do not plan on using DR for normal operations.

For example, you would add the following element to the deployment file when starting your primary database cluster to assign it the unique ID of 3.

```
<dr id="3">
```

Important

An important constraint to be aware of when using this process is that *you must not make any schema changes during the upgrade process*. This includes the period *after* the upgrade while you verify the application's proper operation on the new software version. If any changes are made to the schema, you may not be able to readily fall back to the previous version.

4.4.3.2. The Passive DR Upgrade Process

The procedure for upgrading the VoltDB software on a running database using DR is the following. In the examples, we assume the existing database is running on a cluster with the nodes `oldsvr1` and `oldsvr2` and the new cluster includes servers `newsvr1` and `newsvr2`. We will assign the clusters unique IDs 3 and 4, respectively.

1. Install the new VoltDB software on the secondary cluster.

Follow the steps in the section "Installing VoltDB" in the *Using VoltDB* manual to install the latest VoltDB software.

2. Start the second cluster as a replica of the current database cluster.

Once the new software is installed, create a new database on the secondary server using the `voltdb init --force` and `voltdb start` commands and including the necessary DR configuration to create a replica of the current database. For example, the configuration file on the new cluster might look like this:

```
<dr id="4" role="replica">
  <connection source="oldsvr1,oldsvr2"/>
</dr>
```

Once the second cluster starts, apply the schema from the current database to the second cluster. Once the schema match on the two databases, replication will begin.

3. Wait for replication to stabilize.

During replication, the original database will send a snapshot of the current content to the new replica, then send binary logs of all subsequent transactions. You want to wait until the snapshot is finished and the ongoing DR is processing normally before proceeding.

- First monitor the DR statistics on the new cluster. The DR consumer state changes to "RECEIVE" once the snapshot is complete. You can check this in the Monitor tab of the VoltDB Management Center or from the command line by using `sqlcmd` to call the `@Statistics` system procedure, like so:

```
$ sqlcmd --servers=newsvr1
1> exec @Statistics drconsumer 0;
```

- Once the new cluster reports the consumer state as "RECEIVE", you can monitor the rate of replication on the existing database cluster using the DR producer statistics. Again, you can view these statistics in the Monitor tab of the VoltDB Management Center or by calling `@Statistics` using `sqlcmd`:

```
$ sqlcmd --servers=oldsvr1
1> exec @Statistics drproducer 0;
```

What you are looking for on the producer side is that the DR latency is low; ideally under a second. Because the DR latency helps determine how long you will wait for the cluster to quiesce when you pause it and, subsequently, how long the client applications will be stalled waiting for the new cluster

to be promoted. You determine the latency by looking at the difference between the statistics for the last queued timestamp and the last ACKed timestamp. The difference between these values gives you the latency in microseconds. When the latency reaches a stable, low value you are ready to proceed.

4. Pause the current database.

The next step is to pause the current database. You do this using the **voltadmin pause --wait** command:

```
$ voltadmin pause --host=oldsvr1 --wait
```

The **--wait** flag tells voltadmin to wait until all DR and export queues are flushed to their downstream targets before returning control to the shell prompt. This guarantees that all transactions have reached the new replica cluster.

If DR or export are blocked for any reason — such as a network outage or the target server unavailable — the **voltadmin pause --wait** command will continue to wait and periodically report on what queues are still busy. If the queues do not progress, you will want to fix the underlying problem before proceeding to ensure you do not lose any data.

5. Promote the new database.

Once the current database is fully paused, you can promote the new database, using the **voltadmin promote** command:

```
$ voltadmin promote --host=newsvr1
```

At this point, your database is up and running on the new VoltDB software version.

6. Redirect client applications to the new database.

To restore connectivity to your client applications, redirect them from the old cluster to the new cluster by creating connections to the new cluster servers newsvr1, newsvr2, and so on.

7. Shutdown the original cluster.

At this point you can shutdown the old database cluster.

8. Verify proper operation of the database and client applications.

The last step is to verify that your applications are operating properly against the new VoltDB software. Use the VoltDB Management Center to monitor database transactions and performance and verify transactions are completing at the expected rate and volume.

Your upgrade is now complete. If, at any point, you decide there is an issue with your application or your database, it is possible to fall back to the previous version of VoltDB as long as you have not made any changes to the underlying database schema. The next section explains how to fall back when necessary.

4.4.3.3. Falling Back to a Previous Version

In extreme cases, you may find there is an issue with your application and the latest version of VoltDB. Of course, you normally would discover this during testing prior to a production upgrade. However, if that is not the case and an incompatibility or other conflict is discovered after the upgrade is completed, it is possible to fall back to a previous version of VoltDB. The basic process for falling back is to the following:

- If any problems arise before Step #6 (redirecting the clients) is completed, simply shutdown the new replica and resume the old database using the **voltadmin resume** command:

```
$ voltadmin shutdown --host=newsvr1
```

```
$ voltadmin resume --host=oldsvr1
```

- If issues are found after Step #6, the fall back procedure is basically to repeat the upgrade procedure described in Section 4.4.3.2, “The Passive DR Upgrade Process” except reversing the roles of the clusters and replicating the data from the new cluster to the old cluster. That is:

1. Update the configuration file on the new cluster to enable DR as a master, removing the <connection> element:

```
<dr id="4" role="master" />
```

2. Shutdown the original database and edit the configuration file to enable DR as a replica of the new cluster:

```
<dr id="3" role="replica">  
  <connection source="newsvr1,newsvr2" />  
</dr>
```

3. Re-initialize and start the old cluster using the **voltadb init --force** and **voltadb start** commands.
4. Follow steps 3 through 8 in Section 4.4.3.2, “The Passive DR Upgrade Process” reversing the roles of the new and old clusters.

4.4.4. Performing an Online Upgrade Using Multiple XDCR Clusters

It is also possible to upgrade the VoltDB software using cross data center replication (XDCR), by simply shutting down, upgrading, and then re-initializing each cluster, one at a time. This process requires no downtime, assuming your client applications are already designed to switch between the active clusters.

Use of XDCR for upgrading the VoltDB software is easiest if you are already using XDCR because it does not require any additional hardware or reconfiguration. The following instructions assume that is the case. Of course, you could also create a new cluster and establish XDCR replication between the old and new clusters just for the purpose of upgrading VoltDB. The steps for the upgrade outlined in the following sections are the same. But first you must establish the cross data center replication between the two (or more) clusters. See the chapter on Database Replication in the *Using VoltDB* manual for instructions on completing this initial step.

Once you have two clusters actively replicating data with XDCR (let's call them clusters A and B), the steps for upgrading the VoltDB software on the clusters is as follows:

1. Pause and shutdown cluster A (**voltadmin pause --wait** and **shutdown**).
2. Clear the DR state on cluster B (**voltadmin dr reset**).
3. Update the VoltDB software on cluster A.
4. Start a new database instance on A, making sure to use the old deployment file so the XDCR connections are configured properly (**voltadb init --force** and **voltadb start**).
5. Load the schema on Cluster A so replication starts.
6. Once the two clusters are synchronized, repeat steps 1 through 4 for cluster B.

Note that since you are upgrading the software, you must create a new instance after the upgrade (step #3). When upgrading the software, you cannot recover the database using just the **voltadb start** command;

you must use `voltDB init --force` first to create a new instance and then reload the existing data from the running cluster B.

Also, be sure all data has been copied to the upgraded cluster A after step #4 and before proceeding to upgrade the second cluster. You can do this by checking the `@Statistics` system procedure selector `DR-CONSUMER` on cluster A. Once the `DRCONSUMER` statistics `State` column changes to "RECEIVE", you know the two clusters are properly synchronized and you can proceed to step #5.

4.4.4.1. Falling Back to a Previous Version

In extreme cases, you may decide after performing the upgrade that you do not want to use the latest version of VoltDB. If this happens, it is possible to fall back to the previous version of VoltDB.

To "downgrade" from a new version back to the previous version, follow the steps outlined in Section 4.4.4, "Performing an Online Upgrade Using Multiple XDCR Clusters" except rather than upgrading to the new version in Step #2, reinstall the older version of VoltDB. This process is valid as long as you *have not modified the schema or deployment to use any new or changed features introduced in the new version*.

4.4.5. Performing an Online Upgrade With Limited Hardware

It is possible to use XDCR and K-safety to perform an online upgrade, where the database remains accessible throughout the upgrade process, without requiring an additional cluster. As opposed to upgrading two separate XDCR clusters, this process enables an online upgrade with little or no extra hardware requirements.

On the other hand, this upgrade process is quite complex and during the upgrade, the K-safety of the database is reduced. In other words, this process trades off the need for extra hardware against a more complicated upgrade process and increased risk to availability if any nodes crash unexpectedly during the upgrade.

Essentially, the process for upgrading a cluster with limited additional hardware is to split the existing cluster hardware into two separate clusters, upgrading the software along the way. To make this possible, there are a several prerequisites:

- **The cluster must be configured as a XDCR cluster.**

The cluster configuration must contain a `<dr>` element that identifies the cluster ID and specifies the role as "xdcr". For example:

```
<dr id="1" role="xdcr" />
```

Note that the replication itself can be disabled (that is, `listen="false"`), but the cluster must have the XDCR configuration in place before the online upgrade begins.

- **All of the tables in the database must be identified as DR tables.**

This means that the schema must specify `DR TABLE {table-name}` for all of the tables, or else data for the non-DR tables will be lost.

- **K-Safety must be enabled.**

The K-safety value (set using the `kfactor` attribute of the `<cluster>` element in the configuration file) must be set to one or higher.

Additionally, if the K-safety value is 1 and the cluster has an odd number of nodes, you will need one additional server to complete the upgrade. (The additional server is no longer needed *after* the upgrade is completed.)

Table 4.1, “Overview of the Online Upgrade Process” summarizes the overall process for online upgrade.

Because the process is complicated and requires shutting down and restarting database servers in a specific order, it is important to create an upgrade plan before you begin. The **voltadmin plan_upgrade** command generates such a plan, listing the detailed steps for each phase based on your current cluster configuration. Before you attempt the online upgrade process, use **voltadmin plan_upgrade** to generate the plan and thoroughly review it to make sure you understand what is required.

Table 4.1. Overview of the Online Upgrade Process

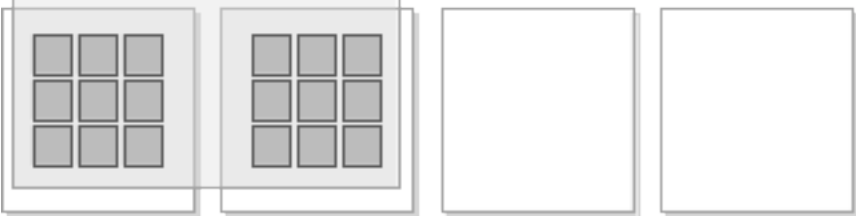
<p>Phase #1</p>	<p>Ensure the cluster meets all the necessary prerequisites (XDCR and K-safety configured, all tables DR-enabled).</p> <p>Install the new VoltDB software version in the same location on all cluster nodes.</p> <p>If not already set, be sure to enable DR for the cluster by setting the listen attribute to true in the cluster configuration.</p> <p>For the purposes of demonstration, the following illustrations assume a four-node database configured with a cluster ID set to 1.</p> <p style="text-align: center;">Cluster id=1 (Version n)</p> 
<p>Phase #2</p>	<p>Stop half the cluster nodes. Because of K-safety, it is possible for half the servers to be removed from the cluster without stopping the database. The plan generated by voltadmin plan_upgrade will tell you exactly which nodes to stop.</p> <p>If the cluster has an odd number of nodes and the K-safety is set to one, you can stop the smaller "half" of the cluster and then add another server to create two equal halves.</p> <p style="text-align: center;">Cluster id=1 (Version n)</p> 
<p>Phase #3</p>	<p>Create a new cluster on the stopped nodes, using the new VoltDB software version. Be sure to configure the cluster with a new cluster ID, XDCR enabled, and listing the original cluster as the DR connection source. You can also start the new cluster using the --missing argument so although it starts with only half the nodes, it expects the full complement of nodes for full k-safety. In the example, the start command would specify --count=2 and --missing=2.</p> <p>After loading the schema and procedures from the original cluster, XDCR will synchronize the two clusters.</p>

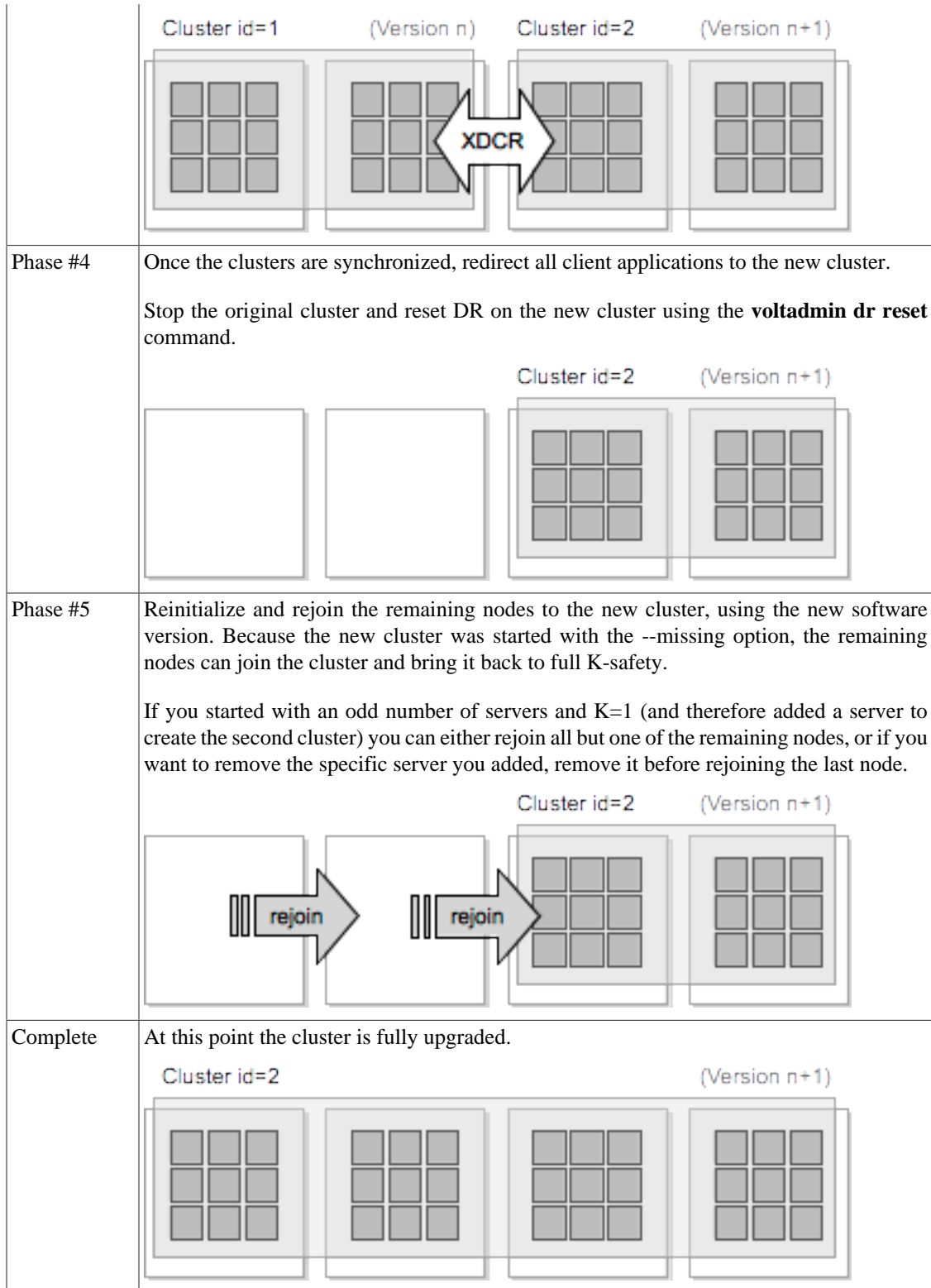

4.4.5.1. Falling Back to the Original Software Version

In extreme cases, you may decide during or after performing the upgrade that you do not want to use the latest version of VoltDB. If this happens, it is possible to fall back to the previous version of VoltDB.

During the phases identified as #1 and #2 in Table 4.1, “Overview of the Online Upgrade Process”, you can always rejoin the stopped nodes to the original cluster to return to your original configuration.

During or after you complete phase #3, you can return to your original configuration by:

1. Stopping the new cluster.
2. Resetting DR on the original cluster (**voltadmin dr reset**).
3. Reinitializing and rejoining the stopped nodes to the original cluster using the original software version.

Once the original cluster is stopped as part of phase #4, the way to revert to the original software version is to repeat the entire procedure starting at phase #1 and reversing the direction — “downgrading” from the new software version to the old software version. This process is valid as long as you *have not modified the schema or deployment to use any new or changed features introduced in the new version.*

Chapter 5. Deploying Clusters with the VoltDB Deployment Manager

The VoltDB Deployment Manager is a tool for simplifying the configuration and starting of VoltDB clusters. The Deployment Manager provides both a web-based interface for interactively configuring and starting clusters and a REST API for remote scripting. The Deployment Manager also integrates with the VoltDB Management Center — the web-based interface for monitoring and managing running databases — to support the entire database lifecycle.

The main component of the VoltDB Deployment Manager is the deployment engine — a daemon process that runs on all servers where you want to manage the deployment of VoltDB databases. The deployment engine comes as part of the VoltDB software kit. So any server with VoltDB installed can start the daemon process and be managed by the Deployment Manager.

5.1. Starting the VoltDB Deployment Manager

There are two ways to start the Deployment Manager: you can start it manually as a process or you can configure and start it as a service. Starting the manager as a process is the simpler method, but requires you to remember to start it each time the system restarts. Configuring the Deployment Manager as a service lets you set it up as a persistent system service, like other common services that are started automatically on system startup.

5.1.1. Starting the Deployment Manager Manually

You start the Deployment Manager manually by starting the daemon process on all participating nodes. The shell command to start the deployment engine is **voltdeploy**. Because this is a daemon process and should be left running, it is a good idea to issue the command as a detached process. For example, by using the **nohup** command:

```
$ nohup voltdeploy &
```

5.1.2. Starting the Deployment Manager as a Service

To start the Deployment Manager as a service, you must first install the files into the appropriate system directories for the Linux configuration service, `/etc/init.d`. You only need to do this once, as long as you install new versions of VoltDB in the same location each time. To install the Deployment Manager files perform the following steps (you will need root privileges):

1. Locate the top-level folder of your VoltDB installation. This is the folder containing the README file and the `/bin`, `/doc`, `/examples`, `/lib`, and `/voltdb` subfolders, among others.
2. Copy `lib/python/vdm/server/voltdeploy` from the VoltDB root directory to the `/etc/init.d/` system folder.
3. Edit the new file `/etc/init.d/voldeploy` and set the environment variable `VOLT_HOME` in the script equal to the VoltDB root. For example, if the root directory is `/home/myaccount/voltdb`:

```
VOLT_HOME=/home/myaccount/voltdb/
```

4. Change the permissions on the script to make it executable:

```
$ sudo chmod a+x /etc/init.d/voltdeploy
```

5. Add the Deployment Manager to the list of services that start and stop automatically with the operating system:

```
$ sudo update-rc.d voltdeploy defaults
```

Once the VoltDB Deployment Manager is installed, you can start, stop, and manage the daemon process like any other system service with the following commands:

```
voltdeploy start  
voltdeploy stop  
voltdeploy reload  
voltdeploy restart  
voltdeploy status
```

5.2. What the Deployment Manager Does

The Deployment Manager assists you in performing four primary tasks:

- Creating a database instance
- Adding and/or removing servers from the database cluster
- Configuring database properties (that is, the deployment file)
- Starting the database

All of these functions can be performed from either the web interface or through the REST API and changes are persisted in the infrastructure regardless of which interface is used.

5.3. How the Deployment Manager Works

The deployment engine runs as a background process, accessible both to operators — through the web or REST interfaces — and to other servers running the deployment engine. For example, say you start the deployment engine on three servers: A, B, and C. You can connect to any one of those servers, define a database, add the other two servers to the cluster and press start, to start a three node database cluster. Note that you only need to connect to one of the servers. That deployment engine takes care of communicating with the servers in the cluster.

What happens is that when you add a server to the database definition, that server sends the full database configuration information to the other servers that are defined part of the cluster. Similarly, when you issue a start command on server A, it takes care of coordinating starting the database process on the other servers, through their deployment engines.

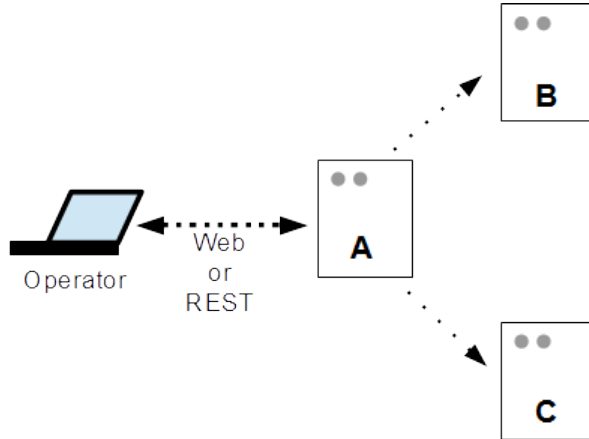

By default, when you connect to a server running the deployment engine, it automatically defines one cluster with one node: the server you are connected to. By issuing the start command you start a one node cluster with the default configuration options, just as if you had run the **voltdb init** and **voltdb start** commands from a command line on that node.

Alternately, you can add more servers to that database definition, as in the diagram. Since the database definitions are automatically copied between the servers whenever a change is made, it doesn't matter which node you are connected to — you can connect to any server defined as part of the cluster to perform deployment tasks.

In fact, you can define multiple databases and the server you are connected to does not even need to be a member of any of those databases, just as long as it has VoltDB installed and the deployment engine daemon running. So you could use one server simply as an administration hub that manages the deployment of databases on other servers.

However, one important point to take note of is that whenever you make a change through one deployment engine, all database definitions from that server are then copied to any server defined as part of the database. So if you connect to the Deployment Manager on two servers and make changes simultaneously, one change will overwrite the other.

5.4. Using the VoltDB Deployment Manager Web Interface

To access the web interface for the VoltDB Deployment Manager, simply point your browser at port 8000 of a server running the deployment engine: <http://server-name:8000/>.

The picture below identifies the main components of the web interface:

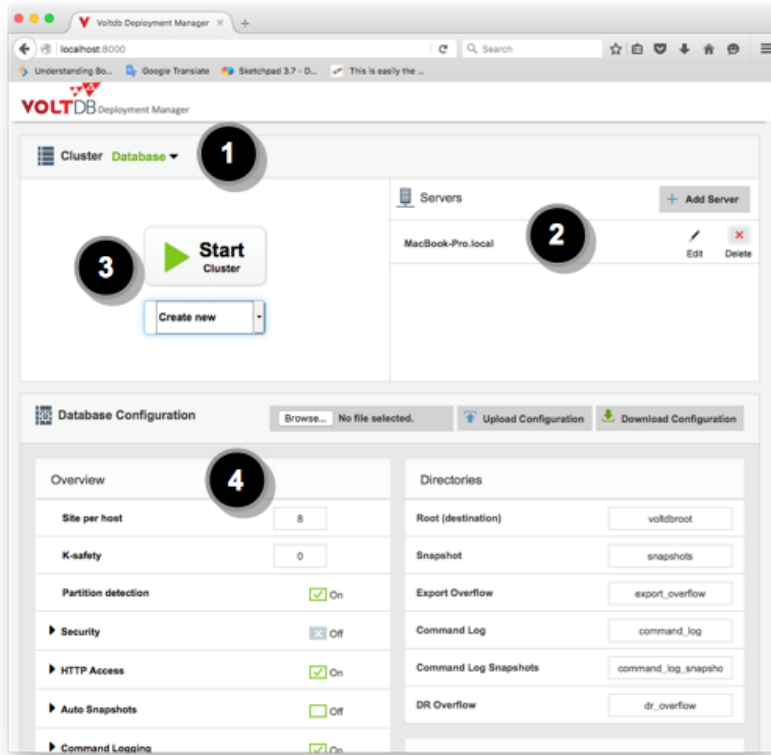

1. Lists the current database. Also can be used to add or delete database definitions.
2. Lists the servers associated with the database cluster. Can be used to add or remove servers from the currently selected database.
3. Starts the current database. If the database is running, links to the VoltDB Management Center on the running database.
4. Let's you customize the configuration options for the current database.

5.5. Using the VoltDB Deployment Manager REST API

You use the REST API by sending HTTP requests to the URL `http://server-name:8000/api/1.0/` of a server running the deployment manager. The following table lists the currently supported REST objects and methods.

Table 5.1. REST API Objects and Methods

URI	GET	POST	PUT	DELETE
<code>/api/1.0/databases/</code>	List databases	Add database		
<code>/api/1.0/databases/{id}</code>	Database object		Update database properties	Delete database

Deploying Clusters with the
VoltDB Deployment Manager

URI	GET	POST	PUT	DELETE
/api/1.0/databases/{id}/deployment	Database deployment that will be used.		Update deployment properties	
/api/1.0/databases/{id}/status	Get Status of database			
/api/1.0/databases/{id}/start			Start Database	
/api/1.0/databases/{id}/recover			Recovers database	
/api/1.0/databases/{id}/stop			Stops database	
/api/1.0/databases/{id}/servers/	Get Server list from database	Add Server		
/api/1.0/databases/{id}/servers/{id}/	Get Server Details of a database		Update	Remove Server
/api/1.0/databases/{id}/servers/{id}/start			Start a Node of a Database (Always do rejoin)	
/api/1.0/databases/{id}/servers/{id}/stop			Stop a Node of a Database	
/api/1.0/databases/{id}/servers/{id}/status	Get Status of node.			

Chapter 6. Monitoring VoltDB Databases

Monitoring is an important aspect of systems administration. This is true of both databases and the infrastructure they run on. The goals for database monitoring include ensuring the database meets its expected performance target as well as identifying and resolving any unexpected changes or infrastructure events (such as server failure or network outage) that can impact the database. This chapter explains:

- How to monitor overall database health and performance using VoltDB
- How to automatically pause the database when resource limits are exceeded
- How to integrate VoltDB monitoring with other enterprise monitoring infrastructures

6.1. Monitoring Overall Database Activity

VoltDB provides several tools for monitoring overall database activity. The following sections describe the three primary monitoring tools within VoltDB:

- VoltDB Management Center
- System Procedures
- SNMP Alerts

6.1.1. VoltDB Management Center

```
http://voltserver:8080/
```

The VoltDB Management Center provides a graphical display of key aspects of database performance, including throughput, memory usage, query latency, and partition usage. To use the Management Center, connect to one of the cluster nodes using a web browser, specifying the HTTP port (8080 by default) as shown in the example URL above. The Management Center shows graphs for cluster throughput and latency as well as CPU and memory usage for the current server. You can also use the Management Center to examine the database schema and to issue ad hoc SQL queries.

6.1.2. System Procedures

VoltDB provides callable system procedures that return detailed information about the usage and performance of the database. In particular, the `@Statistics` system procedure provides a wide variety of information depending on the selector keyword you give it. Some selectors that are particularly useful for monitoring include the following:

- **MEMORY** — Provides statistics about memory usage for each node in the cluster. Information includes the resident set size (RSS) for the server process, the Java heap size, heap usage, available heap memory, and more. This selector provides the type of information displayed by the Process Memory Report, except that it returns information for all nodes of the cluster in a single call.
- **PROCEDUREPROFILE** — Summarizes the performance of individual stored procedures. Information includes the minimum, maximum, and average execution time as well as the number of invocations, failures, and so on. The information is summarized from across the cluster as whole. This selector returns information similar to the latency graph in VoltDB Management Center.

- **TABLE** — Provides information about the size, in number of tuples and amount of memory consumed, for each table in the database. The information is segmented by server and partition, so you can use it to report the total size of the database contents or to evaluate the relative distribution of data across the servers in the cluster.

When using the @Statistics system procedure with the PROCEDUREPROFILE selector for monitoring, it is a good idea to set the second parameter of the call to "1" so each call returns information since the last call. In other words, statistics for the interval since the last call. Otherwise, if the second parameter is "0", the procedure returns information since the database started and the aggregate results for minimum, maximum, and average execution time will have little meaning.

When calling @Statistics with the MEMORY or TABLE selectors, you can set the second parameter to "0" since the results are always a snapshot of the memory usage and table volume at the time of the call. For example, the following Python script uses @Statistics with the MEMORY and PROCEDUREPROFILE selectors to check for memory usage and latency exceeding certain limits. Note that the call to @Statistics uses a second parameter of 1 for the PROCEDUREPROFILE call and a parameter value of 0 for the MEMORY call.

```
import sys
from voltdbclient import *

nano = 1000000000.0
memorytrigger = 4 * (1024*1024)      # 4gbytes
avglatencytrigger = .01 * nano      # 10 milliseconds
maxlatencytrigger = 2 * nano        # 2 seconds

server = "localhost"
if (len(sys.argv) > 1): server = sys.argv[1]

client = FastSerializer(server, 21212)
stats = VoltProcedure( client, "@Statistics",
    [ FastSerializer.VOLTTYPE_STRING,
      FastSerializer.VOLTTYPE_INTEGER ] )

# Check memory
response = stats.call([ "memory", 0 ])
for t in response.tables:
    for row in t.tuples:
        print 'RSS for node ' + row[2] + "=" + str(row[3])
        if (row[3] > memorytrigger):
            print "WARNING: memory usage exceeds limit."

# Check latency
response = stats.call([ "procedureprofile", 1 ])
avglatency = 0
maxlatency = 0
for t in response.tables:
    for row in t.tuples:
        if (avglatency < row[4]): avglatency = row[4]
        if (maxlatency < row[6]): maxlatency = row[6]
print 'Average latency= ' + str(avglatency)
print 'Maximum latency= ' + str(maxlatency)
if (avglatency > avglatencytrigger):
    print "WARNING: Average latency exceeds limit."
if (maxlatency > maxlatencytrigger):
```

```
print "WARNING: Maximum latency exceeds limit."

client.close()
```

The `@Statistics` system procedure is the the source for many of the monitoring options discussed in this chapter. Two other system procedures, `@SystemCatalog` and `@SystemInformation`, provide general information about the database schema and cluster configuration respectively and can be used in monitoring as well.

The system procedures are useful for monitoring because they let you customize your reporting to whatever level of detail you wish. The other advantage is that you can automate the monitoring through scripts or client applications that call the system procedures. The downside, of course, is that you must design and create such scripts yourself. As an alternative for custom monitoring, you can consider integrating VoltDB with existing third party monitoring applications, as described in Section 6.3, “Integrating VoltDB with Other Monitoring Systems”. You can also set the database to automatically pause if certain system resources run low, as described in the next section.

6.1.3. SNMP Alerts

In addition to monitoring database activity on a "as needed" basis, you can enable VoltDB to proactively send Simple Network Management Protocol (SNMP) alerts whenever important events occur within the cluster. SNMP is a standard for how SNMP agents send messages (known as "traps") to management servers or "management stations".

SNMP is a lightweight protocol. SNMP traps are sent as UDP broadcast messages in a standard format that is readable by SNMP management stations. Since they are broadcast messages, the sending agent does not wait for a confirmation or response. And it does not matter, to the sender, whether there is a management server listening to receive the message or not. You can use any SNMP-compliant management server to receive and take action based on the traps.

When you enable SNMP in the deployment file, VoltDB operates as an SNMP agent sending traps whenever management changes occur in the cluster. You enable SNMP with the `<snmp>` element in the deployment file. You configure how and where VoltDB sends SNMP traps using one or more of the attributes listed in Table 6.1, “SNMP Configuration Attributes”.

Table 6.1. SNMP Configuration Attributes

Attribute	Default Value	Description
target	(none)	Specifies the IP address or host name of the SNMP management station where traps will be sent in the form <i>{IP-or-host-name}[:port-number]</i> . If you do not specify a port number, the default is 162. The <code>target</code> attribute is required.
community	public	Specifies the name of the "community" the VoltDB agent belongs to.
username	(none)	Specifies the username for SNMP V3 authentication. If you do not specify a username, VoltDB sends traps in SNMP V2c format. If you specify a username, VoltDB uses SNMP V3 and the following attributes let you configure the authentication mechanisms used.
authprotocol	SHA (SNMP V3 only)	Specifies the authentication protocol for SNMP V3. Allowable options are: <ul style="list-style-type: none"> • SHA

Attribute	Default Value	Description
		<ul style="list-style-type: none"> • MD5 • NoAuth
authkey	voltddbauthkey (SNMP V3 only)	Specifies the authentication key for SNMP V3 when the protocol is other than NoAuth.
privacyprotocol	AES (SNMP V3 only)	Specifies the privacy protocol for SNMP V3. Allowable options are: <ul style="list-style-type: none"> • AES • DES • NoPriv • 3DES* • AES192* • AES256*
privacykey	voltddbprivacykey (SNMP V3 only)	Specifies the privacy key for SNMP V3 when the privacy protocol is other than NoPriv.

*Use of 3DES, AES192, or AES256 privacy requires the Java Cryptography Extension (JCE) be installed on the system. The JCE is specific to the version of Java you are running. See the the Java web site for details.

SNMP is enabled by default when you include the `<snmp>` element in the deployment file. Alternatively, you can explicitly enable and disable SNMP using the `enabled={true|false}` attribute to the element. For example, the following deployment file entry enables SNMP alerts, sending traps to `mgtsvr.mycompany.com` using SNMP V3 with the username "voltddb":

```
<snmp enabled="true"
      target="mgtsvr.mycompany.com"
      username="voltddb"
/>
```

Once SNMP is enabled, VoltDB sends alerts for the events listed in Table 6.2, “SNMP Events”.

Table 6.2. SNMP Events

Name	Severity	Description
crash	FATAL	When a server or cluster crashes.
clusterPaused	INFO	When the cluster pauses and enters admin mode.
clusterResume	INFO	When the cluster exits admin mode and resumes normal operation.
hostDown	ERROR	When a server shuts down or is recognized as having left the cluster.
hostUp	INFO	When a server joins the cluster.
statisticsTrigger	WARN	When certain operational states are compromised. Specifically: <ul style="list-style-type: none"> • When a K-safe cluster loses one or more nodes • When using database replication, the connection to the remote cluster is broken
resourceTrigger	WARN	When certain resource limits are exceeded. Specifically <ul style="list-style-type: none"> • Memory usage • Disk usage

Name	Severity	Description
		See Section 6.2, “Setting the Database to Read-Only Mode When System Resources Run Low” for more information about configuring SNMP alerts for resources.
resourceClear	INFO	When resource limits return to levels below the trigger value.

For the latest details about each event trap, see the VoltDB SNMP Management Information Base (MIB), which is installed with the VoltDB server software in the file `/tools/snmp/VOLTDDB-MIB` in the installation directory.

6.2. Setting the Database to Read-Only Mode When System Resources Run Low

VoltDB, like all software, uses system resources to perform its tasks. First and foremost, as an in-memory database, VoltDB relies on having sufficient memory available for storing the data and processing queries. However, it also makes use of disk resources for snapshots and caching data for other features, such as export and database replication.

If system resources run low, one or more nodes may fail impacting availability, or worse, causing a service interruption. The best solution for this situation is to plan ahead and provision sufficient resources for your needs. The goal of the *VoltDB Planning Guide* is to help you do this.

However, even with the best planning, unexpected conditions can result in resource shortages or overuse. In these situations, you want the database to protect itself against all-out failure.

You can do this by setting resource limits in the VoltDB deployment file. System resource limits are set within the `<systemsettings>` and `<resourcemonitor>` elements. For example:

```
<systemsettings>
  <resourcemonitor frequency="30">
    <memorylimit size="70%" alert="60%"/>
    <disklimit>
      <feature name="snapshots" size="75%" alert="60%"/>
      <feature name="droverflow" size="60%"/>
    </disklimit>
  </resourcemonitor>
</systemsettings>
```

The deployment file lets you set limits on two types of system resources:

- Memory Usage
- Disk Usage

For each resource type you can set the maximum size and, optionally, the level at which an alert is sent if SNMP is enabled. In all cases, the allowable amount of the resource to be used can be specified as either a value representing a number of gigabytes or a percentage of the total available. If the limit set by the `alert` attribute is exceeded and SNMP is enabled, an SNMP alert is sent. If the limit set by the `size` attribute is exceeded, the database will be "paused", putting it into read-only mode to avoid using any further resources or possibly failing when the resource becomes exhausted. When the database pauses, an error message is written to the log file (and the console) reporting the event. This allows you as the system administrator to correct the situation by reducing memory usage or deleting unnecessary files. Once sufficient resources are freed up, you can return the database to normal operation using the **voltadmin resume** command.

The resource limits are checked every 60 seconds by default. However, you can adjust how frequently they are checked — to accommodate the relative stability or volatility of your resource usage — using the `frequency` attribute of the `<resourcemonitor>` tag. In the preceding example, the frequency has been reduced to 30 seconds.

Of course, the ideal is to catch excessive resource use *before* the database is forced into read-only mode. Use of SNMP and system monitors such as Nagios and New Relic to generate alerts at limits lower than the VoltDB resource monitor are strongly recommended. And you can integrate other VoltDB monitoring with these monitoring utilities as described in Section 6.3, “Integrating VoltDB with Other Monitoring Systems”. But the resource monitor `size` limit is provided as a last resort to ensure the database does not completely exhaust resources and crash before the issue can be addressed.

The following sections describe how to set limits for the individual resource types.

6.2.1. Monitoring Memory Usage

You specify a memory limit in the deployment file using the `<memorylimit>` element and specifying the maximum allowable resident set size (RSS) for the VoltDB process in the `size` attribute. You can express the limit as a fixed number of gigabytes or as a percentage of total available memory. Use a percent sign to specify a percentage. For example, the following setting will cause the VoltDB database to go into read-only mode if the RSS size exceeds 10 gigabytes on any of the cluster nodes.

```
<systemsettings>
  <resourcemonitor>
    <memorylimit size="10"/>
  </resourcemonitor>
</systemsettings>
```

Whereas the following example sets the limit at 70% of total available memory.

```
<systemsettings>
  <resourcemonitor>
    <memorylimit size="70%"/>
  </resourcemonitor>
</systemsettings>
```

You can also set a trigger value for SNMP alerts — assuming SNMP is enabled — using the `alert` attribute. For instance, the following example sets the SNMP trigger value to 60%.

```
<systemsettings>
  <resourcemonitor>
    <memorylimit size="70%" alert="60%"/>
  </resourcemonitor>
</systemsettings>
```

If you do not specify a limit in the deployment file, VoltDB automatically sets a maximum size limit of 80% and an SNMP alert level of 70% by default.

6.2.2. Monitoring Disk Usage

You specify disk usage limits in the deployment file using the `<disklimit>` element. Within the `<disklimit>` element, you use the `<feature>` element to identify the limit for a device based on the VoltDB feature that utilizes it. For example, to set a limit on the amount of space used on the device where automatic snapshots are stored, you identify the feature as "snapshots" and specify the limit as a number

of gigabytes or as a percentage of total space on the disk. The following deployment file entry sets the disk limit for snapshots at 200 gigabytes and the limit for command logs at 70% of the total available space:

```
<systemsettings>
  <resourcemonitor>
    <disklimit>
      <feature name="snapshots" size="200"/>
      <feature name="commandlog" size="70%"/>
    </disklimit>
  </resourcemonitor>
</systemsettings>
```

You can also set a trigger value for SNMP alerts — assuming SNMP is enabled — using the `alert` attribute. For instance, the following example sets the SNMP trigger value to 150 gigabytes for the snapshots disk and 60% for the commandlog disk.

```
<systemsettings>
  <resourcemonitor>
    <disklimit>
      <feature name="snapshots" size="200" alert="150"/>
      <feature name="commandlog" size="70%" alert="60%"/>
    </disklimit>
  </resourcemonitor>
</systemsettings>
```

Note that you specify the device based on the feature that uses it. However, the limits applies to *all* data on that device, not just the space used by that feature. If you specify limits for two features that use the same device, the lower of the two limits will be applied. So, in the previous example, if snapshots and command logs both use a device with 250 gigabytes of total space, the database will be set to read-only mode if the total amount of used space exceeds the command logs limit of 70%, or 175 gigabytes.

It is also important to note that there are *no* default resource limits or alerts for disks. If you do not explicitly specify a disk limit, there is no protection against running out of disk space. Similarly, unless you explicitly set an SNMP alert level, no alerts will be sent for the associated device.

You can identify disk limits and alerts for any of the following VoltDB features, using the specified keywords:

- Automated snapshots (snapshots)
- Command logs (commandlog)
- Command log snapshots (commandlogsnapshot)
- Database replication overflow (droverflow)
- Export overflow (exportoverflow)

6.3. Integrating VoltDB with Other Monitoring Systems

In addition to the tools and system procedures that VoltDB provides for monitoring the health of your database, you can also integrate this data into third-party monitoring solutions so they become part of your overall enterprise monitoring architecture. VoltDB supports integrating VoltDB statistics and status with the following monitoring systems:

- Nagios
- New Relic

6.3.1. Integrating with Nagios

If you use Nagios to monitor your systems and services, you can include VoltDB in your monitoring infrastructure. VoltDB Enterprise Edition provides Nagios plugins that let you monitor four key aspects of VoltDB. The plugins are included in a subfolder of the tools directory where VoltDB is installed. Table 6.3, “Nagios Plugins” lists each plugin and what it monitors.

Table 6.3. Nagios Plugins

Plugin	Monitors	Scope	Description
check_voltodb_ports	Availability	Server	Reports whether the specified server is reachable or not.
check_voltodb_memory	Memory usage	Server	Reports on the amount of memory in use by VoltDB for a individual node. You can specify the severity criteria as a percentage of total memory.
check_voltodb_cluster	K-safety	Cluster-wide	Reports on whether a K-safe cluster is complete or not. That is, whether the cluster has the full complement of nodes or if any have failed and not re-joined yet.
check_voltodb_replication	Database replication	Cluster-wide	Reports the status of database replication. Connect the plugin to one or more nodes on the master database.

Note that the `httpd` and `JSON` options must be enabled in the deployment file for the VoltDB database for the Nagios plugins to query the database status.

6.3.2. Integrating with New Relic

If you use New Relic as your monitoring tool, there is a VoltDB plugin to include monitoring of VoltDB databases to your New Relic dashboard. To use the New Relic plugin, you must:

- Define the appropriate configuration for your server.
- Start the `voltodb-newrelic` process that gathers and sends data to New Relic.

You define the configuration by editing and renaming the template files that can be found in the `/tools/monitoring/newrelic/config` folder where VoltDB is installed. The configuration files let you specify your New Relic license and which databases are monitored. A `README` file in the `/newrelic` folder provides details on what changes to make to the configuration files.

You start the monitoring process by running the script `voltodb-newrelic` that also can be found in the `/newrelic` folder. The script must be running for New Relic to monitor your databases.

Chapter 7. Logging and Analyzing Activity in a VoltDB Database

VoltDB uses Log4J, an open source logging service available from the Apache Software Foundation, to provide access to information about database events. By default, when using the VoltDB shell commands, the console display is limited to warnings, errors, and messages concerning the status of the current process. A more complete listing of messages (of severity INFO and above) is written to log files in the subfolder `/log`, relative to the database root directory.

The advantages of using Log4J are:

- Logging is compiled into the code and can be enabled and configured at run-time.
- Log4J provides flexibility in configuring what events are logged, where, and the format of the output.
- By using an open source logging service with standardized output, there are a number of different applications, such as Chainsaw, available for filtering and presenting the results.

Logging is important because it can help you understand the performance characteristics of your application, check for abnormal events, and ensure that the application is working as expected.

Of course, any additional processing and I/O will have an incremental impact on the overall database performance. To counteract any negative impact, Log4J gives you the ability to customize the logging to support only those events and servers you are interested in. In addition, when logging is not enabled, there is no impact to VoltDB performance. With VoltDB, you can even change the logging profile on the fly without having to shutdown or restart the database.

The following sections describe how to enable and customize logging of VoltDB using Log4J. This chapter is **not** intended as a tutorial or complete documentation of the Log4J logging service. For general information about Log4J, see the Log4J web site at <http://wiki.apache.org/logging-log4j/>.

7.1. Introduction to Logging

Logging is the process of writing information about application events to a log file, console, or other destination. Log4J uses XML files to define the configuration of logging, including three key attributes:

- **Where** events are logged. The destinations are referred to as *appenders* in Log4J (because events are appended to the destinations in sequential order).
- **What** events are logged. VoltDB defines named classes of events (referred to as *loggers*) that can be enabled as well as the severity of the events to report.
- **How** the logging messages are formatted (known as the *layout*),

7.2. Creating the Logging Configuration File

VoltDB ships with a default Log4J configuration file, `voltldb/log4j.xml`, in the installation directory. The sample applications and the VoltDB shell commands use this file to configure logging and it is recommended for new application development. This default Log4J file lists all of the VoltDB-specific logging categories and can be used as a template for any modifications you wish to make. Or you can create a new file from scratch.

The following is an example of a Log4J configuration file:

```
<?xml version="1.0" encoding="UTF-8" ?>
<!DOCTYPE log4j:configuration SYSTEM "log4j.dtd">

<log4j:configuration xmlns:log4j="http://jakarta.apache.org/log4j/">

<appender name="Async" class="org.apache.log4j.AsyncAppender">
  <param name="Blocking" value="true" />
  <appender-ref ref="Console" />
  <appender-ref ref="File" />
</appender>

<appender name="Console" class="org.apache.log4j.ConsoleAppender">
  <param name="Target" value="System.out" />
  <layout class="org.apache.log4j.TTCCLayout" />
</appender>

<appender name="File" class="org.apache.log4j.FileAppender">
  <param name="File" value="/tmp/voltdb.log" />
  <param name="Append" value="true" />
  <layout class="org.apache.log4j.TTCCLayout" />
</appender>

<logger name="AUTH">
<!-- Print all VoltDB authentication messages -->
  <level value="trace" />
</logger>

<root>
  <priority value="debug" />
  <appender-ref ref="Async" />
</root>
</log4j:configuration>
```

The preceding configuration file defines three destinations, or appenders, called *Async*, *Console*, and *File*. The appenders define the type of output (whether to the console, to a file, or somewhere else), the location (such as the file name), as well as the layout of the messages sent to the appender. See the log4J documentation for more information about layout.

Note that the appender *Async* is a superset of *Console* and *File*. So any messages sent to *Async* are routed to both *Console* and *File*. This is important because for logging of VoltDB, you should always use an asynchronous appender as the primary target to avoid the processing of the logging messages from blocking other execution threads.

More importantly, you should not use any appenders that are susceptible to extended delays, blockages, or slow throughput. This is particularly true for network-based appenders such as *SocketAppender* and third-party log infrastructures including *logstash* and *JMS*. If there is any prolonged delay in writing to the appenders, messages can end up being held in memory causing performance degradation and, ultimately, generating out of memory errors or forcing the database into read-only mode.

The configuration file also defines a root class. The root class is the default logger and all loggers inherit the root definition. So, in this case, any messages of severity "debug" or higher are sent to the *Async* appender.

Finally, the configuration file defines a logger specifically for VoltDB authentication messages. The logger identifies the class of messages to log (in this case "AUTH"), as well as the severity ("trace"). VoltDB

defines several different classes of messages you can log. Table 7.1, “VoltDB Components for Logging” lists the loggers you can invoke.

Table 7.1. VoltDB Components for Logging

Logger	Description
ADHOC	Execution of ad hoc queries
AUTH	Authentication and authorization of clients
COMPILER	Interpretation of SQL in ad hoc queries
CONSOLE	Informational messages intended for display on the console
DR	Database replication sending data
DRAGENT	Database replication receiving data
EXPORT	Exporting data
GC	Java garbage collection
HOST	Host specific events
IMPORT	Importing data
JOIN	Elastic addition of nodes to the cluster
LOADER	Bulk loading of data (including as part of import)
NETWORK	Network events related to the database cluster
REJOIN	Node recovery and rejoin
SNAPSHOT	Snapshot activity
SQL	Execution of SQL statements
TM	Transaction management

7.3. Enabling Logging for VoltDB

Once you create your Log4J configuration file, you specify which configuration file to use by defining the variable `LOG4J_CONFIG_PATH` before starting the VoltDB database. For example:

```
$ LOG4J_CONFIG_PATH="$HOME/MyLog4jConfig.xml"
$ voltdb start -H svr1,svr2
```

7.4. Changing the Timezone of Log Messages

By default all VoltDB logging is reported in GMT (Greenwich Mean Time). If you want the logging to be reported using a different timezone, you can use extensions to the Log4J service to achieve this.

To change the timezone of log messages:

1. Download the extras kit from the Apache Extras for Apache Log4J website, <http://logging.apache.org/log4j/extras/>.
2. Unpack the kit and place the included JAR file in the `/lib/extension` folder of the VoltDB installation directory.
3. Update your Log4J configuration file to enable the Log4J extras and specify the desired timezone for logging for each appender.

You enable the Log4J extras by specifying `EnhancedPatternLayout` as the layout class for the appenders you wish to change. You then identify the desired timezone as part of the layout pattern. For example, the following XML fragment changes the timezone of messages written to the file appender to GMT minus four hours:

```
<appender name="file" class="org.apache.log4j.DailyRollingFileAppender">
  <param name="file" value="log/volt.log"/>
  <param name="DatePattern" value="'.'yyyy-MM-dd" />
  <layout class="org.apache.log4j.EnhancedPatternLayout">
    <param name="ConversionPattern"
      value="%d{ISO8601}{GMT-4} %-5p [%t] %c: %m%n"/>
  </layout>
</appender>
```

You can use any valid ISO-8601 timezone specification, including named timezones, such as EST.

7.5. Changing the Configuration on the Fly

Once the database has started, you can still start or reconfigure the logging without having to stop and restart the database. By calling the system procedure `@UpdateLogging` you can pass the configuration XML to the servers as a text string. For any appenders defined in the new updated configuration, the existing appender is removed and the new configuration applied. Other existing appenders (those not mentioned in the updated configuration XML) remain unchanged.

Chapter 8. What to Do When Problems Arise

As with any high performance application, events related to the database process, the operating system, and the network environment can impact how well or poorly VoltDB performs. When faced with performance issues, or outright failures, the most important task is identifying and resolving the root cause. VoltDB and the server produce a number of log files and other artifacts that can help you in the diagnosis. This chapter explains:

- Where to look for log files and other information about the VoltDB server process
- What to do when recovery fails
- How to collect the log files and other system information when reporting a problem to VoltDB

8.1. Where to Look for Answers

The first place to look when an unrecognized problem occurs with your VoltDB database is the console where the database process was started. VoltDB echoes key messages and errors to the console. For example, if a server becomes unreachable, the other servers in the cluster will report an error indicating which node has failed. Assuming the cluster is K-safe, the remaining nodes will then re-establish a quorum and continue, logging this event to the console as well.

However, not all messages are echoed on the console.¹ A more complete record of errors, warnings, and informational messages is written to a log file, `log/volt.log`, inside the `voltbroot` directory. So, for example, if you start the database using the command `voltdb start --dir=~/db`, the log file is `~/db/voltbroot/log/volt.log`.² The `volt.log` file can be extremely helpful for identifying unexpected but non-fatal events that occurred earlier and may identify the cause of the current issue.

If VoltDB encounters a fatal error and exits, shutting down the database process, it also attempts to write out a crash file in the current working directory. The crash file name has the prefix "voltdb_crash" followed by a timestamp identifying when the file is created. Again, this file can be useful in diagnosing exactly what caused the crash, since it includes the last error message, a brief profile of the server and a dump of the Java threads running in the server process before it crashed.

To summarize, when looking for information to help analyze system problems, three places to look are:

1. The console where the server process was started.
2. The log file in `log/volt.log`
3. The crash file named `voltdb_crash{timestamp}.txt` in the server process's working directory

8.2. Handling Errors When Restoring a Database

After determining what caused the problem, the next step is often to get the database up and running again as soon as possible. When using snapshots or command logs, this is done using the `voltdb start` command described in Section 3.6, "Restarting the Database". However, in unusual cases, the restart itself may fail.

¹Note that you can change which messages are echoed to the console and which are logged by modifying the Log4j configuration file. See the chapter on logging in the *Using VoltDB* manual for details.

²When using the older `voltdb` commands `create`, `recover`, `rejoin`, and `add`, the `log/volt.log` file is created under the current working directory where the command is issued rather than in the root directory.

There are several situations where an attempt to recover a database — either from a snapshot or command logs — may fail. For example, restoring data from a snapshot to a schema where a unique index has been added can result in a constraint violation. In this case, the restore operation continues but any records that caused a constraint violation are saved to a CSV file.

Or when recovering command logs, the log may contain a transaction that originally succeeded but fails and raises an exception during playback. In this situation, VoltDB issues a fatal error and stops the database to avoid corrupting the contents.

Although protecting you from an incomplete recovery is the appropriate default behavior, there may be cases where you want to recover as much data as possible, with full knowledge that the resulting data set does *not* match the original. VoltDB provides two processes for performing partial recoveries in case of failure:

- Logging constraint violations during snapshot restore
- Performing command log recovery in safe mode

The following sections describe these procedures.

Warning

It is critically important to recognize that the techniques described in this section *do not* produce a complete copy of the original database or resolve the underlying problem that caused the initial recovery to fail. These techniques should never be attempted without careful consideration and full knowledge and acceptance of the risks associated with partial data recovery.

8.2.1. Logging Constraint Violations

There are several situations that can cause a snapshot restore to fail because of constraint violations. Rather than have the operation fail as a whole, VoltDB continues with the restore process and logs the constraint violations to a file instead. This way you can review the tuples that were excluded and decide whether to ignore or replace their content manually after the restore completes.

By default, the constraint violations are logged to one or more files (one per table) in the same directory as the snapshot files. In a cluster, each node logs the violations that occur on that node. If you know there are going to be constraint violations and want to save the logged constraints to a different location, you can use a special JSON form of the `@SnapshotRestore` system procedure. You specify the path of the log files in a JSON attribute, `duplicatePaths`. For example, the following commands perform a restore of snapshot files in the directory `/var/voltdb/snapshots/` with the unique identifier `myDB`. The restore operation logs constraint violations to the directory `/var/voltdb/logs`.

```
$ sqlcmd
1> exec @SnapshotRestore '{ "path": "/var/voltdb/snapshots/",
                           "nonce": "myDB",
                           "duplicatesPath": "/var/voltdb/logs/" }';
2> exit
```

Constraint violations are logged as needed, one file per table, to CSV files with the name `{table}-duplicates-{timestamp}.csv`.

8.2.2. Safe Mode Recovery

On rare occasions, recovering a database from command logs may fail. This can happen, for example, if a stored procedure introduces non-deterministic content. If a recovery fails, the specific error is known.

However, there is no way for VoltDB to know the root cause or how to continue. Therefore, the recovery fails and the database stops.

When this happens, VoltDB logs the last successful transaction before the recovery failed. You can then ask VoltDB to restart up to but not including the failing transaction by performing a recovery in *safe mode*.

You request safe mode by adding the **--safemode** switch to the **voltldb start** command, like so:

```
$ voltldb start --safemode --dir=~ /mydb
```

When VoltDB recovers from command logs in safe mode it enables two distinct behaviors:

- Snapshots are restored, logging any constraint violations
- Command logs are replayed up to the last valid transaction

This means that if you are recovering using an automated snapshot (rather than command logs), you can recover some data even if there are constraint violations during the snapshot restore. Also, when recovering from command logs, VoltDB will ignore constraint violations in the command log snapshot and replay all transactions that succeeded in the previous attempt.

It is important to note that to successfully use safe mode with command logs, you must perform a regular recovery operation first — and have it fail — so that VoltDB can determine the last valid transaction. Also, if the snapshot and the command logs contain both constraint violations and failed transactions, you may need to run recovery in safe mode twice to recover as much data as possible. Once to complete restoration of the snapshot, then a second time to recover the command logs up to a point before the failed transaction.

8.3. Collecting the Log Files

VoltDB includes a utility that collects all of the pertinent logs for a given server. The log collector retrieves the necessary system and process files from the server, creates a compressed archive file and, optionally, uploads it via SFTP to a support site. For customers requesting support from VoltDB, your support contact will often provide instructions on how and when to use the log collector and where to submit the files.

Note that the database does not need to be running to use the log collector. It can find and collect the log files based solely on the location of the VoltDB root directory where the database was run.

To collect the log files, use the **voltldb collect** command:

```
$ voltldb collect --prefix=mylogs /home/db/voltldbroot
```

When you run the command you must specify the location of the root directory for the database as an argument to the command. For example, if you are in the same directory where the database was originally started (as specified by the **--dir** flag), the root directory is the subdirectory **voltldbroot**.

```
$ voltldb collect --prefix=mylogs $(pwd)/voltldbroot
```

The archive file that the **collect** command generates is created in your current working directory.

The **collect** command has optional arguments that let you control what data is collected, the name of the resulting archive file, as well as whether to upload the file to an FTP server. In the preceding example the **--prefix** flag specifies the prefix for the archive file name. If you are submitting the log files to an FTP server via SFTP, you can use the **--upload**, **--username**, and **--password** flags to identify the target server and account. For example:

```
$ voltldb collect --prefix=mylogs \
```

```
--upload=ftp.mycompany.com \  
--username=babbage  
--password=charles /home/db/voltdbroot
```

Note that the **voltdb collect** command collects log files for the current system only. To collect logs for all servers in a cluster, you will need to issue the **voltdb collect** command locally on each server separately. See the **voltdb collect** documentation in the *Using VoltDB* manual for details.

Appendix A. Server Configuration Options

There are a number of system, process, and application options that can impact the performance or behavior of your VoltDB database. You control these options when initializing and/or starting VoltDB. The configuration options fall into five main categories:

- Server configuration
- Process configuration
- Database configuration
- Path configuration
- Network ports used by the database cluster

This appendix describes each of the configuration options, how to set them, and their impact on the resulting VoltDB database and application environment.

A.1. Server Configuration Options

VoltDB provides mechanisms for setting a number of options. However, it also relies on the base operating system and network infrastructure for many of its core functions. There are operating system configuration options that you can adjust to to maximize your performance and reliability, including:

- Network configuration
- Time configuration

A.1.1. Network Configuration (DNS)

VoltDB creates a network mesh among the database cluster nodes. To do that, all nodes must be able to resolve the IP address and hostnames of the other server nodes. Make sure all nodes of the cluster have valid DNS entries or entries in the local hosts files.

For servers that have two or more network interfaces — and consequently two or more IP addresses — it is possible to assign different functions to each interface. VoltDB defines two sets of ports:

- External ports, including the client and admin ports. These are the ports used by external applications to connect to and communicate with the database.
- Internal ports, including all other ports. These are the ports used by the database nodes to communicate among themselves. These include the internal port, the zookeeper port, and so on. (See Section A.5, “Network Ports” for a complete listing of ports.)

You can specify which network interface the server expects to use for each set of ports by specifying the internal and external interface when starting the database. For example:

```
$ voltdb start --dir=~ /mydb \  
-H serverA -l license.xml \  
--externalinterface=10.11.169.10 \  
--internalinterface=10.12.171.14
```

Note that the default setting for the internal and external interface can be overridden for a specific port by including the interface and a colon before the port number when specifying a port on the command line. See Section A.5, “Network Ports” for details on setting specific ports.

A.1.2. Time Configuration (NTP)

Keeping VoltDB cluster nodes in close synchronization is important for the ongoing performance of your database. At a minimum, use of NTP to synchronize time across the cluster is recommended. If the time difference between nodes is too large (greater than 200 milliseconds) VoltDB refuses to start. It is also important to avoid having nodes adjust time backwards, or VoltDB will pause while it waits for time to "catch up" to its previous setting.

A.2. Process Configuration Options

In addition to system settings, there are configuration options pertaining to the VoltDB server process itself that can impact performance. Runtime configuration options are set as command line options when starting the VoltDB server process.

The key process configuration for VoltDB is the Java maximum heap size. It is also possible to pass other arguments to the Java Virtual Machine directly.

A.2.1. Maximum Heap Size

The heap size is a parameter associated with the Java runtime environment. Certain portions of the VoltDB server software use the Java heap. In particular, the part of the server that receives and responds to stored procedure requests uses the Java heap.

Depending upon how many transactions your application executes a second, you may need additional heap space. The higher the throughput, the larger the maximum heap needed to avoid running out of memory.

In general, a maximum heap size of two gigabytes (2048) is recommended. For production use, a more accurate measurement of the needed heap size can be calculated from the size of the schema (number of tables), number of sites per host, and what durability and availability features are in use. See the *VoltDB Planning Guide* for details.

It is important to remember that the heap size is not directly related to data storage capacity. Increasing the maximum heap size does not provide additional data storage space. In fact, quite the opposite. Needlessly increasing the maximum heap size reduces the amount of memory available for storage.

To set the maximum heap size when starting VoltDB, define the environment variable `VOLTDB_HEAPMAX` as an integer value (in megabytes) before issuing the `voltdb start` command. For example, the following commands start VoltDB with a 3 gigabyte heap size (the default is 2 gigabytes):

```
$ export VOLTDB_HEAPMAX="3072"
$ voltdb start --dir=~ /mydb -H serverA
```

A.2.2. Other Java Runtime Options (VOLTDB_OPTS)

VoltDB sets the Java options — such as heap size and classpath — that directly impact VoltDB. There are a number of other configuration options available in the Java Virtual machine (JVM).

VoltDB provides a mechanism for passing arbitrary options directly to the JVM. If the environment variable `VOLTDB_OPTS` is defined, its value is passed as arguments to the Java command line. Note that

the contents of `VOLTDB_OPTS` are added to the Java command line on the current server only. In other words, you must define `VOLTDB_OPTS` on each server to have it take effect for all servers.

Warning

VoltDB does not validate the correctness of the arguments you specify using `VOLTDB_OPTS` or their appropriateness for use with VoltDB. This feature is intended for experienced users only and should be used with extreme caution.

A.3. Database Configuration Options

Runtime configuration options are set either as part of the configuration file or as command line options when starting the VoltDB server process. These database configuration options are only summarized here. See the *Using VoltDB* manual for a more detailed explanation. The configuration options include:

- Sites per host
- K-Safety
- Network partition detection
- Read level consistency
- Automated snapshots
- Import and export
- Command logging
- Heartbeat
- Temp table size
- Query timeout
- Long-running process warning

A.3.1. Sites per Host

Sites per host specifies the number of unique VoltDB "sites" that are created on each physical database server. The section on "Determining How Many Sites per Host" in the *Using VoltDB* manual explains how to choose a value for sites per host.

You set the value of sites per host using the `sitesperhost` attribute of the `<cluster>` tag in the configuration file.

A.3.2. K-Safety

K-safety defines the level of availability or durability that the database can sustain, by replicating individual partitions to multiple servers. K-safety is described in detail in the "Availability" chapter of the *Using VoltDB* manual.

You specify the level of K-safety that you want in the configuration file using the `kfactor` attribute of the `<cluster>` tag.

A.3.3. Network Partition Detection

Network partition detection protects a VoltDB cluster in environments where the network is susceptible to partial or intermittent failure among the server nodes. Partition detection is described in detail in the "Availability" chapter of the *Using VoltDB* manual.

Use of network partition detection is strongly recommended for production systems and therefore is enabled by default. You can enable or disable network partition detection in the configuration file using the `<partition-detection>` tag.

A.3.4. Read Level Consistency

In a highly available cluster (that is, a VoltDB cluster using K-safety), write transactions are executed on all copies of a partition. This guarantees data consistency across the cluster. By default, read transactions are also processed on all copies of the partition, using *safe* read level consistency.

Since the data is the same on all copies of the partition, it is possible to optimize read transactions by processing the queries on a single copy of the partition only. However, using this *fast* read level consistency, read transactions can access data modified by write transactions on the local server, before all nodes confirm those write transactions. During a node failure or network partition, it is possible that the locally completed writes could be rolled back as part of the network partition resolution. Of course, this only happens when the read transaction accesses data modified by an immediately preceding write that is not committed on all copies of the partition prior to a network partition.

If you do not need guaranteed read consistency in all cases, you can choose to have the cluster produce faster read transactions by setting the read level consistency to "fast" in the deployment file, so read transactions are processed on only one copy of the partition. To set the read level consistency, use the `<consistency>` element in the configuration file and set the `readlevel` attribute to either "safe" (the default) or "fast". For example:

```
<consistency readlevel="fast"/>
```

A.3.5. Automated Snapshots

Automated snapshots provide ongoing protection against possible database failure (due to hardware or software issues) by taking periodic snapshots of the database's contents. Automated snapshots are described in detail in the section on "Scheduling Automated Snapshots" in the *Using VoltDB* manual.

You enable and configure automated snapshots with the `<snapshot>` tag in the configuration file.

Snapshot activity involves both processing and disk I/O and so may have a noticeable impact on performance (in terms of throughput and/or latency) on a very busy database. You can control the priority of snapshots activity using the `<snapshot/>` tag within the `<systemsettings>` element of the deployment file. The snapshot priority is an integer value between 0 and 10, with 0 being the highest priority and 10 being the lowest. The closer to 10, the longer snapshots take to complete, but the less they can affect ongoing database work.

Note that snapshot priority affects all snapshot activity, including automated snapshots, manual snapshots, and command logging snapshots.

A.3.6. Import and Export

The import and export functions let you automatically import and/or export selected data between your VoltDB database and another database or distributed service at runtime. These features are described in detail in the chapter on "Importing and Exporting Live Data" in the *Using VoltDB* manual.

You enable and disable import and export using the `<import>` and `<export>` tags in the configuration file.

A.3.7. Command Logging

The command logging function saves a record of each transaction as it is initiated. These logs can then be "replayed" to recreate the database's last known state in case of intentional or accidental shutdown. This feature is described in detail in the chapter on "Command Logging and Recovery" in the *Using VoltDB* manual.

To enable and disable command logging, use the `<commandlog>` tag in the configuration file.

A.3.8. Heartbeat

The database servers use a "heartbeat" to verify the presence of other nodes in the cluster. If a heartbeat is not received within a specified time limit, that server is assumed to be down and the cluster reconfigures itself with the remaining nodes (assuming it is running with K-safety). This time limit is called the "heartbeat timeout" and is specified as an integer number of seconds.

For most situations, the default value for the timeout (10 seconds) is appropriate. However, if your cluster is operating in an environment that is susceptible to network fluctuations or unpredictable latency, you may want to increase the heartbeat timeout period.

You can set an alternate heartbeat timeout using the `<heartbeat>` tag in the configuration file.

Note

Be aware that certain Linux system settings can override the VoltDB heartbeat messages. In particular, lowering the setting for `TCP_RETRIES2` may result in the system network timeout interrupting VoltDB's heartbeat mechanism and causing timeouts sooner than expected. Values lower than 8 for `TCP_RETRIES2` are not recommended.

A.3.9. Temp Table Size

VoltDB uses temporary tables to store intermediate table data while processing transactions. The default temp table size is 100 megabytes. This setting is appropriate for most applications. However, extremely complex queries or many updates to large records could cause the temporary space to exceed the maximum size, resulting in the transaction failing with an error.

In these unusual cases, you may need to increase the temp table size. You can specify a different size for the temp tables using the `<temptables>` tag in the configuration file and specifying a whole number of megabytes. Note: since the temp tables are allocated as needed, increasing the maximum size can result in a Java out-of-memory error at runtime if the system is memory-constrained. Modifying the temp table size should be done with caution.

A.3.10. Query Timeout

In general, SQL queries execute extremely quickly. But it is possible, usually by accident, to construct a query that takes an unexpectedly long time to execute. This usually happens when the query is overly complex or accesses extremely large tables without the benefit of an appropriate filter or index.

You have the option to set a query timeout limit cluster-wide, for an interactive session, or per transaction. The query limit sets a limit on the length of time any read-only query (or batch of queries in the case of

the `voltExecuteSQL()` method in a stored procedure) is allowed to run. You specify the timeout limit in milliseconds.

To set a cluster-wide query limit you use the `<systemsettings>` and `<query timeout="{limit}">` tags in the configuration file. To set a limit for an interactive session in the `sqlcmd` utility, you use the `--query-timeout` flag when invoking `sqlcmd`. To specify a limit when invoking a specific stored procedure, you use the `callProcedureWithTimeout` method in place of the `callProcedure` method.

The cluster-wide limit is set when you initialize the database root directory. By default, the system-wide limit is 10 seconds. You can set a different timeout in the configuration file. Or It can be adjusted using the **`voltadmin update`** command to modify the configuration settings while the database is running. If security is enabled, any user can set a lower query limit on a per session or per transaction basis. However, the user must have the `ADMIN` privilege to set a query limit longer than the cluster-wide setting.

The following example configuration file sets a cluster-wide query timeout value of three seconds:

```
<systemsettings>
  <query timeout="3000"/>
</systemsettings>
```

If any query or batch of queries exceeds the query timeout, the query is interrupted and an error returned to the calling application. Note that the limit is applied to read-only ad hoc queries or queries in read-only stored procedures only. In a K-Safe cluster, queries on different copies of a partition may execute at different rates. Consequently the same query may timeout in one copy of the partition but not in another. To avoid possible non-deterministic changes, VoltDB does not apply the time out limit to any queries or procedures that may modify the database contents.

A.3.11. Long-Running Process Warning

You can avoid runaway read-only queries using the query timeout setting. But you cannot stop read-write procedures or other computational tasks, such as automated snapshots. These processes must run to completion. However, you may want to be notified when a process is blocking an execution queue for an extended period of time.

By default, VoltDB writes an informational message into the log file whenever a task runs for more than ten seconds in any of the execution sites. These tasks may be stored procedures, procedure fragments (in the case of multi-partitioned procedures), or operational tasks such as snapshot creation. You can adjust the limit when these messages are written by specifying a value, in milliseconds in the `loginfo` attribute of the `<procedure>` tag in the configuration file. For example, the following configuration file entry changes the threshold after which a message is written to the log to three seconds:

```
<systemsettings>
  <procedure loginfo="3000"/>
</systemsettings>
```

Note that in a cluster, the informational message is written only to the log of the server that is hosting the affected queue, not to all server logs.

A.4. Path Configuration Options

The running database uses a number of disk locations to store information associated with runtime features, such as export, network partition detection, and snapshots. You can control which paths are used for these disk-based activities. The path configuration options include:

- VoltDB root
- Snapshots path
- Export overflow path
- Command log path
- Command log snapshots path

A.4.1. VoltDB Root

VoltDB defines a root directory for any disk-based activity which is required at runtime. This directory also serves as a root for all other path definitions that take the default or use a relative path specification.

If you do not specify a location for the root directory on the command line, VoltDB uses the current working directory as a default. Normally, you specify the location of the root directory using the `--dir` flag on the **voltdb init** and **voltdb start** commands. The root directory is then the subdirectory `voltddbroot` within the specified location. (If the subfolder does not exist, VoltDB creates it.) See the section on "Configuring Paths for Runtime Features" in the *Using VoltDB* manual for details.

A.4.2. Snapshots Path

The snapshots path specifies where automated and network partition snapshots are stored. The default snapshots path is the "snapshots" subfolder of the VoltDB root directory. You can specify an alternate path for snapshots using the `<snapshots>` child element of the `<paths>` tag in the configuration file.

A.4.3. Export Overflow Path

The export overflow path specifies where overflow data is stored if the export queue gets too large. The default export overflow path is the "export_overflow" subfolder of the VoltDB root directory. You can specify an alternate path using the `<exportoverflow>` child element of the `<paths>` tag in the configuration file.

See the chapter on "Exporting Live Data" in the *Using VoltDB* manual for more information on export overflow.

A.4.4. Command Log Path

The command log path specifies where the command logs are stored when command logging is enabled. The default command log path is the "command_log" subfolder of the VoltDB root directory. However, for production use, it is strongly recommended that the command logs be written to a dedicated device, not the same device used for snapshotting or export overflow. You can specify an alternate path using the `<commandlog>` child element of the `<paths>` tag in the configuration file.

See the chapter on "Command Logging and Recovery" in the *Using VoltDB* manual for more information on command logging.

A.4.5. Command Log Snapshots Path

The command log snapshots path specifies where the snapshots created by command logging are stored. The default path is the "command_log_snapshot" subfolder of the VoltDB root directory. (Note that command log snapshots are stored separately from automated snapshots.) You can specify an alternate path using the `<commandlogsnapshot>` child element of the `<paths>` tag in the configuration file.

See the chapter on "Command Logging and Recovery" in the *Using VoltDB* manual for more information on command logging.

A.5. Network Ports

A VoltDB cluster opens network ports to manage its own operation and to provide services to client applications. When using the command line, the network ports are configurable as part of the command that starts the VoltDB database process or through the configuration file. When specifying a port on the command line, you can specify just a port number or the network interface and the port number, separated by a colon.

Table A.1, "VoltDB Port Usage" summarizes the ports that VoltDB uses, their default value, and how to change the default. The following sections describe each port in more detail. Section A.5.8, "TLS/SSL Encryption (Including HTTPS)" explains how to enable TLS encryption for the web port and the programming interface ports, client and admin.

Table A.1. VoltDB Port Usage

Port	Default Value	How to Set
Client Port	21212	VoltDB start command
Admin Port	21211	VoltDB start command line or configuration file
Web Interface Port (httpd)	8080	VoltDB start command line or configuration file
Web Interface Port (with TLS/SSL enabled)	8443	VoltDB start command line or configuration file
Internal Server Port	3021	VoltDB start command line
Replication Port	5555	VoltDB start command line
Zookeeper port	7181	VoltDB start command line

A.5.1. Client Port

The client port is the port VoltDB client applications use to communicate with the database cluster nodes. By default, VoltDB uses port 21212 as the client port. You can change the client port. However, all client applications must then use the specified port when creating connections to the cluster nodes.

To specify a different client port on the command line, use the `--client` flag when starting the VoltDB database. For example, the following command starts the database using port 12345 as the client port:

```
$ voltdb start -l ~/license.xml \
  --dir=~ /mydb -H serverA \
  --client=12345
```

If you change the default client port, all client applications must also connect to the new port. The client interfaces for Java and C++ accept an additional, optional argument to the `createConnection` method for this purpose. The following examples demonstrate how to connect to an alternate port using the Java and C++ client interfaces.

Java

```
org.voltdb.client.Client voltclient;
voltclient = ClientFactory.createClient();
```

```
voltclient.createConnection("myserver",12345);
```

C++

```
boost::shared_ptr<voltdb::Client> client = voltdb::Client::create();  
client->createConnection("myserver", 12345);
```

A.5.2. Admin Port

The admin port is similar to the client port, it accepts and processes requests from applications. However, the admin port has the special feature that it continues to accept write requests when the database enters admin, or read-only, mode.

By default, VoltDB uses port 21211 on the default external network interface as the admin port. You can change the port assignment in the configuration file using the `<admin-mode>` tag or on the command line using the `--admin` flag. For example, the following configuration file sets the admin port to 2222:

```
<deployment>  
  ...  
  <admin-mode port="2222" />  
</deployment>
```

The same effect can be achieved using the `--admin` flag on the command line:

```
$ voltdb start -l ~/license.xml \  
  --dir=~ /mydb -H serverA \  
  --admin=2222
```

When the admin port is set in both the configuration file and on the command line, the command line setting supersedes the configuration file.

A.5.3. Web Interface Port (httpd)

The web interface port is the port that VoltDB listens to for web-based connections. This port is used for both the JSON interface and access to the VoltDB Management Center. There are two related attributes associated with the web interface. The first attribute is whether the port is enabled. If the port is not enabled, then neither the JSON interface nor the Management Center are available from the cluster. The second attribute is which port to use. (Note that you can also use the `--http` flag on the command line to set the httpd port.) By default, the web interface is enabled and the default port is 8080.

You can also enable TLS (Transport Layer Security) encryption on the web interface so that all interaction uses the HTTPS protocol. When TLS is enabled, the default port changes to 8443. See Section A.5.8, “TLS/SSL Encryption (Including HTTPS)” for information on enabling encryption in the configuration file.

A.5.4. JSON Interface

In addition to the overall availability and port for the web interface, you can also specify separately whether the JSON interface is available. To enable the httpd port but disable the JSON interface, specify the attribute `enabled="false"` in the `<jsonapi>` tag in the deployment file when starting VoltDB. For example, the following deployment file fragment enables the web interface and the JSON interface, specifying the alternate port 8083.

```
<httpd port="8083">  
  <jsonapi enabled="true"/>  
</httpd>
```

If you change the port number, be sure to use the new port number when connecting to the cluster using the JSON interface. For example, the following URL connects to the port 8083, instead of 8080:

```
http://athena.mycompany.com:8083/api/1.0/?Procedure=@SystemInformation
```

For more information about the JSON interface, see the section on "How the JSON Interface Works" in the *Using VoltDB* manual.

A.5.5. Internal Server Port

A VoltDB cluster uses ports to communicate among the cluster nodes. This port is internal to VoltDB and should not be used by other applications.

By default, the internal server port is port 3021 for all nodes in the cluster¹. You can specify an alternate port using the `--internal` flag when starting the VoltDB process. For example, the following command starts the VoltDB process using an internal port of 4000:

```
$ voltdb start -l ~/license.xml \  
  --dir=~ /mydb -H serverA \  
  --internal=4000
```

A.5.6. Replication Port

During database replication, the replica uses a dedicated port to connect to the master database. By default, the replication port is port 5555. You can use a different port by specifying a different port number either on the `voltdb` command line or in the configuration file.

- On the command line, use the `--replication` flag to specify a different port (and, optionally, a different network interface):

```
$ voltdb start -l ~/license.xml \  
  --dir=~ /mydb -H serverA \  
  --replication=6666
```

- In the configuration file, specify the replication port number using the `port` attribute of the `<dr>` tag:

```
<dr id="3" port="6666" />
```

Adding the replication port to the configuration file is useful when setting the port for all nodes in the cluster. Using the command line option is useful for changing the default port for only one node in the cluster or for specifying a specific network interface. If you specify the replication port in both the configuration file and on the command line, the command line argument takes precedence.

A.5.7. Zookeeper Port

VoltDB uses a version of Apache Zookeeper to communicate among supplementary functions that require coordination but are not directly tied to database transactions. Zookeeper provides reliable synchronization for functions such as command logging without interfering with the database's own internal communications.

VoltDB uses a network port bound to the local interface (127.0.0.1) to interact with Zookeeper. By default, 7181 is assigned as the Zookeeper port for VoltDB. You can specify a different port number using the

¹In the special circumstance where multiple VoltDB processes are started for one database, all on the same server, the internal server port is incremented from the initial value for each process.

`--zookeeper` flag when starting the VoltDB process. It is also possible to specify a different network interface, like with other ports. However, accepting the default for the zookeeper network interface is recommended where possible. For example:

```
$ voltdb start -l ~/license.xml \  
  --dir=~ /mydb -H serverA \  
  --zookeeper=2288
```

A.5.8. TLS/SSL Encryption (Including HTTPS)

VoltDB lets you enable Transport Layer Security (TLS) — the recommended upgrade from Secure Socket Layer (SSL) encryption — for all of its externally-facing interfaces: the web port, the client port, and the admin port. You can either enable TLS for just the web port or for all three external ports.

To enable TLS encryption you need an appropriate certificate. How you configure TLS depends on whether you create a local certificate or receive one from an authorized certificate provider, such as VeriSign, GeoTrust and others. If you use a commercial certificate, you only need to identify the certificate as the key store. If you create your own, you must specify both the key store and the trust store. (See the section on using TLS/SSL for security in the Using VoltDB manual for an example of creating your own certificate.)

You enable TLS encryption in the deployment file using the `<ssl>` element. Within `<ssl>` you specify the location and password for the key store and, for locally generated certificates, the trust store in separate elements like so:

```
<ssl>  
  <keystore path="/etc/mydb/keystore" password="twiddledee"/>  
  <truststore path="/etc/mydb/truststore" password="twiddledum"/>  
</ssl>
```

By default, when you include the `<ssl>` element in the configuration file, TLS encryption is enabled for the web port and all access to the `httpd` port and JSON interface must use the HTTPS protocol. When you enable TLS, the default web port changes from 8080 to 8443.

You can explicitly enable or disable TLS encryption by including the `enable` attribute. (For example, if you want to include the key store and trust store in the configuration but not turn on TLS during testing, you can include `enabled="false"`.) You can specify that the client and admin API ports are also TLS encrypted by adding the `external` attribute and setting it to `true`. For example, the following configuration sample, explicitly enables TLS for all three ports:

```
<ssl enabled="true" external="true">  
  <keystore path="/etc/mydb/keystore" password="twiddledee"/>  
  <truststore path="/etc/mydb/truststore" password="twiddledum"/>  
</ssl>
```

Note that you *cannot* disable TLS encryption for the web port separately. TLS is always enabled for the web port if you enable encryption for the other two external ports.

Appendix B. Snapshot Utilities

VoltDB provides two utilities for managing snapshot files. These utilities verify that a native snapshot is complete and usable and convert the snapshot contents to a text representation that can be useful for uploading or reloading data in case of severe errors.

It is possible, as the result of a design flaw or failed program logic, for a database application to become unusable. However, the data is still of value. In such emergency cases, it is desirable to extract the data from the database and possibly reload it. This is the function that `save` and `restore` perform within VoltDB.

But there may be cases when you want to use the data created by a VoltDB snapshot elsewhere. The goal of the utilities is to assist in that process. The snapshot utilities are:

- `snapshotconvert` converts a snapshot (or part of a snapshot) into text files, creating one file for each table in the snapshot.
- `snapshotverifier` verifies that a VoltDB snapshot is complete and usable.

To use the `snapshotconvert` and `snapshotverifier` commands, be sure that the `voltodb/bin` directory is in your `PATH`, as described in the section on "Setting Up Your Environment" in the *Using VoltDB* manual. The following sections describe how to use these two commands.

snapshotconvert

snapshotconvert — Converts the tables in a VoltDB snapshot into text files.

Syntax

```
snapshotconvert {snapshot-id} --type {csv|tsv} \
    --table {table} [...] [--dir {directory}]... \
    [--outdir {directory}]

snapshotconvert --help
```

Description

SnapshotConverter converts one or more tables in a valid snapshot into either comma-separated (csv) or tab-separated (tsv) text files, creating one file per table.

Where:

{snapshot-id}	is the unique identifier specified when the snapshot was created. (It is also the name of the .digest file that is part of the snapshot.) You must specify a snapshot ID.
{csv tsv}	is either "csv" or "tsv" and specifies whether the output file is comma-separated or tab-separated. This argument is also used as the filetype of the output files.
{table}	is the name of the database table that you want to export to text file. You can specify the <code>--table</code> argument multiple times to convert multiple tables with a single command.
{directory}	is the directory to search for the snapshot (<code>--dir</code>) or where to create the resulting output files (<code>--outdir</code>). You can specify the <code>--dir</code> argument multiple times to search multiple directories for the snapshot files. Both <code>--dir</code> and <code>--outdir</code> are optional; they default to the current directory path.

Example

The following command exports two tables from a snapshot of the flight reservation example used in the *Using VoltDB* manual. The utility searches for the snapshot files in the current directory (the default) and creates one file per table in the user's home directory:

```
$ snapshotconvert flightsnap --table CUSTOMER --table RESERVATION \
    --type csv --outdir ~/
```

snapshotverifier

snapshotverifier — Verifies that the contents of one or more snapshot files are complete and usable.

Syntax

```
snapshotverifier [snapshot-id] [--dir {directory}] ...  
snapshotverifier --help
```

Description

SnapshotVerifier verifies one or more snapshots in the specified directories.

Where:

[snapshot-id]	is the unique identifier specified when the snapshot was created. (It is also the name of the .digest file that is part of the snapshot.) If you specify a snapshot ID, only snapshots matching that ID are verified. If you do not specify an ID, all snapshots found will be verified.
{directory}	is the directory to search for the snapshot. You can specify the <code>--dir</code> argument multiple times to search multiple directories for snapshot files. If you do not specify a directory, the default is to search the current directory.

Examples

The following command verifies all of the snapshots in the current directory:

```
$ snapshotverifier
```

This example verifies a snapshot with the unique identifier "flight" in either the directory `/etc/voltdb/save` or `~/mysaves`:

```
$ snapshotverifier flight --dir /etc/voltdb/save/ --dir ~/mysaves
```